

股票代码 603915

GUOMAO
国 茂 股 份



传动精品 传递真情

摆线针轮减速机 Cycloidal Reducer

产品样本 NO.002
版本 V3.5-2022

Product Overview

产品总览

NO.001



G系列减速机

G Series Gear Reducer

NO.002



摆线针轮减速机

Cycloidal Reducer

NO.003

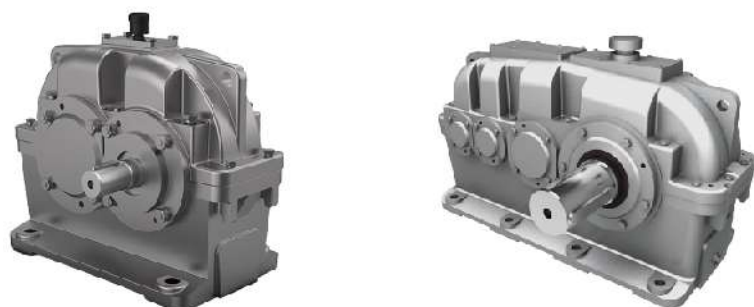

ZY系列圆柱齿轮减速机

ZY Series Cylindrical Gear Reducer

NO.003B



DBY/DCY系列圆锥圆柱 齿轮减速机

DBY/DCY Series Sevel Gear
Reducer

NO.004



HB系列工业齿轮箱

HB Series Gear Box

NO.005

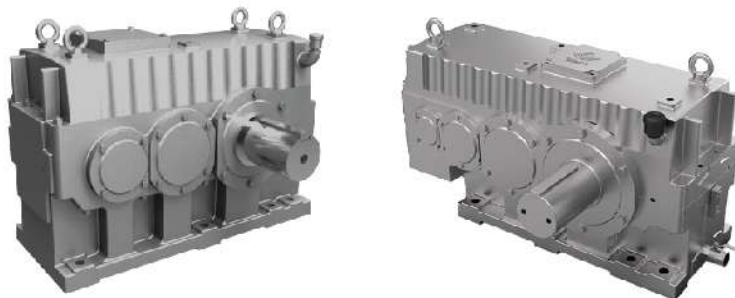

GM系列齿轮减速机

GM Series Reducer

NO.005B

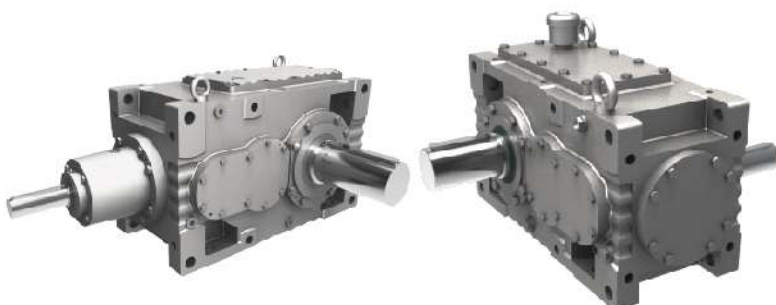

GMC系列齿轮减速机

GMC Series Reducer

NO.006

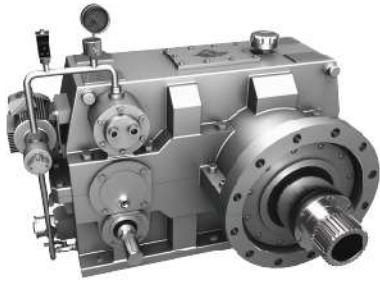

橡塑专用减速机

Plastic and Rubber Special Reducer

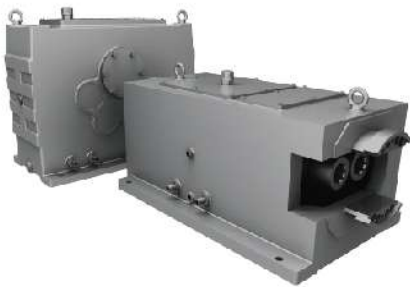

NO.007



GX系列行星齿轮减速机

GX Series Planetary Gear Reducer

NO.008



工程机械减速机

Engineering Machinery Reducer

NO.009



精密减速机

Precision Reducer

NO.010



重载齿轮箱

Heavy-duty Gearbox

NO.011



交流感应伺服电机

Ac Induction Servo Motor

NO.012



起重专用减速机

Lifting Special Reducer



Cycloidal Reducer

摆线针轮减速机

Contents

目录

1	产品概述	1
1.1	产品特性	1
1.2	内部构造	1
1.3	型号一览	1
1.4	型号表示方法	2
1.5	减速比一览	2
1.6	配置电机接线盒位置及入线口表示方法	3
1.7	安装型式图例	3
1.8	减速机各种标准机型对照表	3
2	选型资料	4
2.1	选型步骤	4
2.2	工况系数一览	5
2.3	选型参数释义	6
2.4	径向力校核	7
2.5	选型参数表注释	7
2.6	选型参数表	8
3	外形及安装尺寸	22
3.1	BW、BWD、XW、XWD型 (单级) 外形安装尺寸	22
3.2	BL、BLD、XLW、XLD型 (单级) 外形安装尺寸	23
3.3	BWE、BWED、XWE、XWED型 (双级) 外形安装尺寸	24
3.4	BLE、BLED、XLE、XLED型 (双级) 外形安装尺寸	25
3.5	电机接盘型联接法兰尺寸图表	26
3.6	三相异步电机-B5外形及安装尺寸	28
3.7	IEC电动机形位公差要求	29
3.8	减速机及电机重量	31
4	使用及润滑须知	33
4.1	使用须知	33
4.2	润滑须知	34
5	化工反应罐机架	35
5.1	JBT型 (79标) 搪玻璃反应罐机架	35
5.2	DJ、LDJ型机架	36
5.3	SJ、LSJ型机架	37
5.4	DXJ型机架	38
5.5	JXD型机架	39
5.6	JXLD型机架 (74标) (天津标)	40
5.7	TJ型机架	41
5.8	TJQ型机架	42
5.9	TJA (新标) 型机架	43
5.10	JAI大法兰机架 (69标) 与JAI搪玻璃反应罐专用机架 (69标)	44

1 产品概述

1.1 产品特性

摆线针轮减速机是参照JB/T2982采用少齿差行星式传动原理及摆线针齿啮合的新颖传动机械，广泛应用于纺织印染、轻工食品、冶金矿工、石油化工、起重运输及工程机械等领域中的驱动和减速装置。

1) 高速比和效率高

单级传动，就能达到1：87的减速比，效率在90%以上，如果采用多级传动，减速比更大。

2) 结构紧凑体积小

采用行星传动原理，输入轴和输出轴在同一轴心上，结构紧凑，体积小。

3) 装拆方便，容易维修

结构设计合理，拆装简单，便于维修。

4) 运转平稳噪声低

摆线针齿啮合齿数较多，重叠系数大以及具有机件平稳的机理，使振动和噪声控制在最小程度。

5) 使用可靠寿命长

主要传动啮合件采用轴承钢制造、机械性能好，圆滑的滚动摩擦，更经久耐用寿命长。

6) 过载能力强、耐冲击、惯性力矩小

适用于启动频繁和正反转的场合。

1.2 内部构造

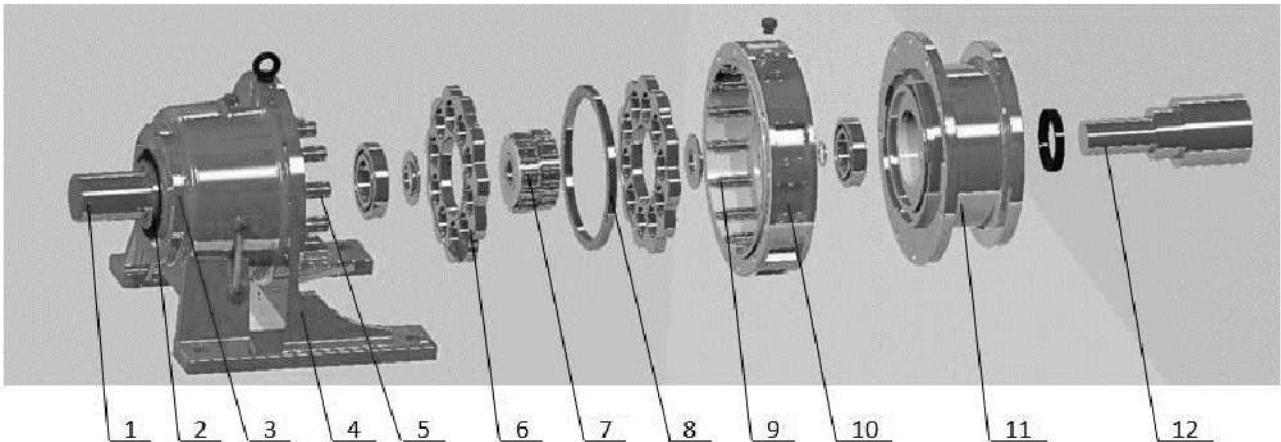

1.输出轴 2.紧固环 3.小端盖 4.机座 5.销轴、销套 6.摆线轮 7.偏心轴承 8.间隔环 9.针齿销、针齿套 10.针齿壳
11.电机接头 12.输入轴

1.3 型号一览

一级	B系列	09	0	1	2	3	4		5	6	7	8	9	
	X系列	1	2	3	4	5	6	7	8	9	10	11	12	
二级	B系列	10	20	31	41	42	52	53	63	64	74	84	85	95
	X系列	32	42	53	63	64	84	85	95	96	106	117	118	128
三级	B系列	2009	320	420	531	631	742	852	953					
	X系列	421	542	642	853	953	1064	1184	1285					

1.4 型号表示方法

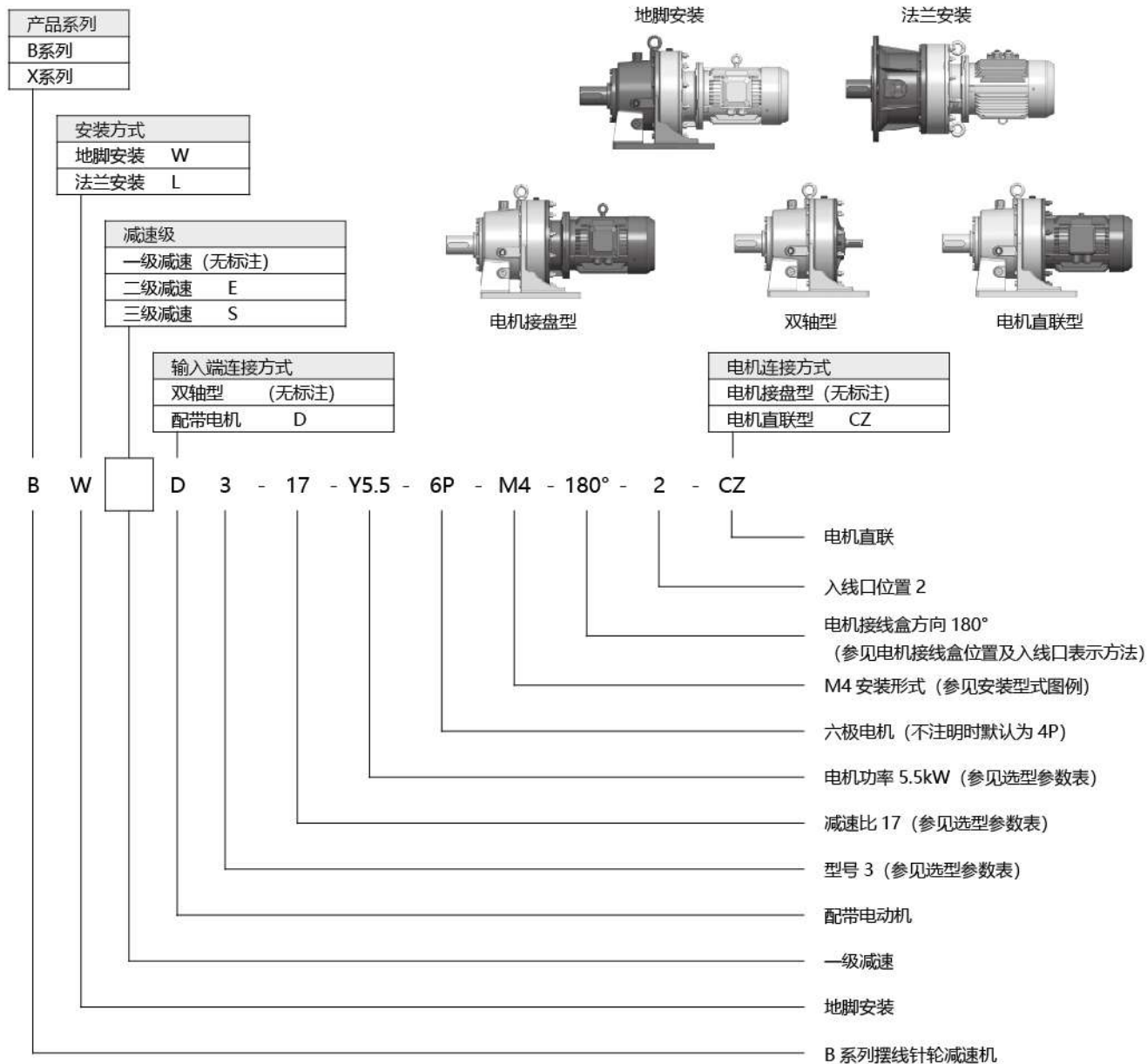

1.5 减速比一览

一级	7	9	11	13	15	17	19	23
	29	35	43	59	71	87		
二级	99 (11×9)	121 (11×11)	187 (17×11)	289 (17×17)	319 (29×11)	391 (23×17)	493 (29×17)	595 (35×17)
	649 (59×11)	731 (43×17)	841 (29×29)	1003 (59×17)	1225 (35×35)	1357 (59×23)	1505 (43×35)	1849 (43×43)
	2065 (59×35)	2537 (59×43)	3053 (71×43)	3481 (59×59)	4189 (71×59)	5133 (87×59)	6177 (87×71)	7569 (87×87)
三级	8041 ~ 658503							

注: 1. 凡一级传动提供的减速比, 二级、三级传动均可组合;
2. 二级、三级减速比一般组合原则为: 高速端为减速比小的一端, 低速端为减速比大的一端。

1.6 配置电机接线盒位置及入线口表示方法

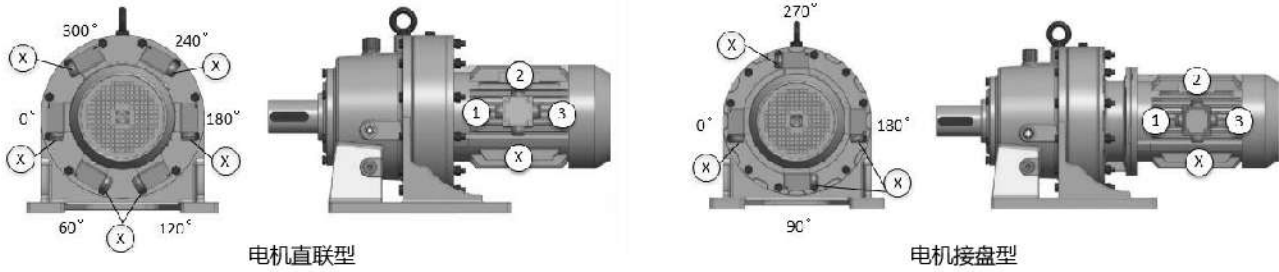

- 注：1. 不注明接线盒方向时，则默认为图示中的0°位置；不注明入线口位置时，则默认为X位置；
 2. 图示中接线盒方向为常用配置，请优先使用；
 3. 上图也同样适用于二级、三级传动机型。
 4. 如有其它特殊要求，请与我们公司技术部联系。

1.7 安装型式图例

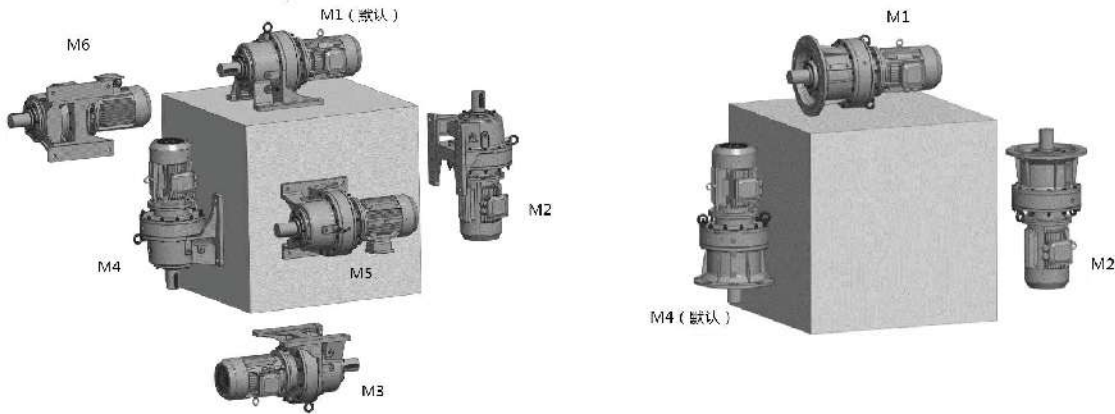

注：地脚式安装时，M1为默认安装型式；法兰式安装时，M4为默认安装型式。（书写型号时可忽略）请优先选用。

1.8 减速机各种标准机型对照表

减速机标准	一级													
	JB/T2982-94A	X1	X2	X3	X4	X5	X6	X7	X8	X9	X10	X11	X12	
JB/T2982-94B	B09	B0	B1	B2	B3	B4		B5	B6	B7	B8	B9		
JB/T2982-81		B12	B15	B18	B22	B27		B33	B39	B45	B55	B65		
上海标	B10A	B10	B11	B12	B13	B14	B14A	B15	B16	B17	B18	B19		
			B11A	B12B	B13B				B16B					
减速机标准	二级													
JB/T2982-94A	X32	X42	X53	X63	X64	X74	X84	X85	X95	X96	X106	X117	X118	X128
JB/T2982-94B	B10	B20	B31	B41	B42		B52	B53	B63	B64	B74	B84	B85	B95
JB/T2982-81	B1512	B1812	B2215	B2715	B2718		B3318	B3322	B3922	B3927	B4527	B5527	B5533	B6533
上海标	B110A	B120A	B131A	B141A	B142A		B152	B153	B163	B164	B174	B184A		B195

注：不同标准相应机型号，性能指标基本相同，外形、安装和联接尺寸略有不同。以上型号我公司均可生产，请优先选用JB/T2982标准产品。

2 选型资料

2.1 选型步骤

1. 安装方式的选用

一般由用户根据安装布置形式来确定。

2. 实际工况系数 f_A 的确定

1) 一般使用要求

f_A 主要由工作机的载荷特性、工作时间和起停次数决定。即： $f_A = f_{Ah} \times f_{Ac}$ 。

式中 f_{Ah} 是由载荷特性和工作时间两个因素决定的工况系数。常用工作机的 f_{Ah} 可参考工况系数 f_{Ah} 选定。其他工作机的工况系数，可用类比法确定。

式中 f_{Ac} 由启、停次数决定。可参考表工况系数 f_{Ac} 确定。注意启、停要各计一次。

2) 特殊使用要求

若环境温度特别高，要考虑增加温度工况系数 f_{At} 。可参考表工况系数 f_{At} 确定。

若要减速机具有特别高的可靠性，则要增加必要的安全系数 f_{As} 。

数值不能确定时，请与我公司技术部联系。

3. 型号（规格）的确定

必须满足 $f_B \geq f_A$

1) 电机与减速机直联或通过联轴器联接

a、在选型参数表中找到相应的电机功率、极数。

b、在此功率和极数下，初步选用一个具有相近传动比的机型，并记录其使用系数 f_B 。

c、比较，若满足条件 $f_B \geq f_A$ ，则就是可用机型。否则，加大机型，直到满足条件。

2) 电机与减速机之间具有前置减速联接

如电机与减速机之间通过齿轮、皮带、链轮等减速装置联接，由于输入转矩的增加，须把电机功率折算到减速机输入轴上，即把电机功率乘以前置减速装置的传动比。用折算的功率，按前述（1）中的方法选取。此时，仍要注意电机极数不变。

4. 径向载荷校验

减速机轴头装有齿轮、皮带轮、链轮时，将产生较大的径向载荷。此时，必须进行径向载荷检验。方法见选型参数释义中有关内容。若径向载荷超出许用值，可选用更大规格机型。

2.2 工况系数一览

工况系数 f_{Ah}							
应用	8h/天	16h/天	24h/天	应用	8h/天	16h/天	24h/天
食品工业				磨机			
粉碎机	1.75	2	2.25	球磨机, 棒磨机	1.75	1.75	1.75
甜菜切片机 揉面机	1.25	1.5	1.75	锤磨机, 粉碎机	1.5	1.75	2
碾肉机	1.25	1.5	1.5	印刷和制纸技术			
填充机	0.8~1*	1	1.25	切割机	1	1.25	1.5
和面机	1	1.25	1.5	卷筒	0.8~1*	1	1.25
挤压机	1.25	1.5	1.75	打包进料机	1	1.25	1.25
甘蔗切碎机	1.75	1.75	1.75	电梯			
榨糖机	1.75	1.75	1.75	提升机	1.25	1.5	1.75
烤面包机	1.25	1.25	1.25	货运电梯	1.25	1.5	1.75
辅助动力、伺服电机				自动扶梯	1.25	1.25	1.5
微动装置, 无载荷	0.8~1*			纺织工业			
普通载荷	1.25	1.25	1.25	织机	1.25	1.5	1.75
压缩机				纺纱机	0.8~1*	1	1.25
离心式	1	1.25	1.5	洗涤机	1	1.25	1.5
轴流式	1	1.25	1.5	输送机			
过滤机	1	1.25	1.5	斗式输送机	1.5	1.75	1.75
建筑业				平衡加荷或喂料	0.8~1*	1	1.25
水泥搅拌机	1.25	1.5	1.75	重载链和螺旋输送	1.25	1.5	1.5
水泥厂	1.5	1.75	2	振动输送机	1.5	1.75	2
灰泥喷射机	0.8~1*	1	1.25	卷扬机	1.5	1.75	1.75
发电机	0.8~1*	1	1.25	皮带输送机	1.25	1.5	1.5
水处理、环保				绞车	1.5	1.75	1.75
曝气机	1.75	2	2	刮板式输送机	1.25	1.25	1.5
普通通风装置	1.5	1.5	1.5	风扇			
旋转木马式通风装置	1.75	1.75	1.75	离心式风扇	0.8~1*	1	1.25
条栅式筛子 搜集器	0.8~1*	1	1.25	工业风扇	1	1.25	1.5
螺旋泵	1	1.25	1.5	冷却塔动力	1.75	1.75	1.75
筛子				冷却塔风扇	1.75	2	2
旋转式(石头、砂)	1	1.25	1.5	包装机械			
行进式吸水机	0.8~1*	1	1.25	纸板堆叠机械	1.25	1.5	1.75
农用机械				打包机	0.8~1*	1	1.25
施肥平土机	0.8~1*	1		机床设备			
收割机	0.8~1*	1		平面刨床, 龙门刨床, 弯轧机	1.25	1.5	1.75
起重机械							
行走机构	1.5	1.75	2	主动力, 进给动力	1	1.25	1.5
回转机构	1.25	1.5	2	进给和辅助动力	0.8~1*	1	1.25
起升机构	1.25	1.5	1.75	压力机	1.75	2	2
转臂式起重机	1.25	1.5	1.75	折弯机	1.5	1.75	2
混合机				剪板机	1.75	2	2
均匀密度	1.25	1.5	1.5	钢铁工业			
不均匀密度	1.5	1.75	1.75	拉线机	1.25	1.5	1.75
木材和塑料工业				绕线机	1.25	1.75	1.75
电锯的主动力	1.5	1.75	2	轧辊辊道: 无回转			
电锯的进给动力	1	1.25	1.5	-组合拉力	1.25	1.5	1.75
砍木机	1.5	1.75	2	-独立动力	1.5	1.75	2
胶合板胶合机	0.8~1*	1	1.25	泵			
钻孔机	0.8~1*	1	1.25	离心式风扇	1	1.25	1.5
挤压机	1.25	1.5	1.75	旋转式, 齿轮型, 叶轮型, 叶片型	0.8~1*	1	1.25
搅拌机				活塞泵: 单缸	1.5	1.75	2
纯液体(均匀密度)	1.25	1.5	1.5	多缸	1.25	1.5	1.75
非均匀密度的液体	1.5	1.75	2	螺旋泵	1	1.25	1.5
液体和固体	1.5	1.75	2				

工况系数 f_{Ac}	
启停次数/每小时	
< 10	1
< 100	1.15
< 500	1.25

工况系数 f_{At}					
环境	+20°C...	+20°C...	+30°C...	+40°C...	+50°C...
温度		+30°C...	+40°C...	+50°C...	+60°C...
f_{At}	1	1.05	1.15	1.3	1.5

注: *=0.8, 假如运行时间少于3小时/天, 并无径向载荷作用。

这些工况系数特别适用于电机作为主要动力的场合。对于特殊应用设计, 例如启停及正反转频繁场合, 请与我们公司技术部联系。

2.3 选型参数释义

选型参数表:

P[kW]: 电机功率。

n_a [r/min]: 输出转速。参考电机满载时的转速和减速机的传动比计算得出, 单位为转/分钟。

M_a [Nm]: 电机满载时输出轴上可以产生的转矩。此输出转矩已考虑了减速机的传动效率。

[i]: 减速机从输入到输出间的减速比。

F_{ra} [kN]: 输出轴轴伸中点处的许用径向载荷 (载荷作用点在轴端处时, 表中 F_{ra} 应乘以0.4)。工作元件的实际径向载荷 F_r 与实际工况系数 f_A 的乘积不得大于此值, 即 $f_A \times F_r \leq F_{ra}$ (f_A 可参照选型步骤2中说明)。

一般工作元件的 F_r 值可由下式求出:

$$F_r = M_r \times f_r / r \quad (\text{N})$$

其中: M_r —工作元件的工作转矩 (Nm)

r —工作元件节圆半径 (m)

f_r —径向载荷系数 (可参考如下取值)

单排链轮	$f_r=1$	V型带	$f_r=1.5$
一个齿轮或双排链轮	$f_r=1.25$	平型带	$f_r=2.5$

f_B : 使用系数, 减速机额定功率与所配用的电机额定功率的比值。它是选择减速器规格的强度依据。

机型号: 即减速机的机型和规格号 (详见减速机型号一览)。其结构尺寸可查阅相应的外形安装尺寸图表。

极数: 电机极数, 减速机可配置四极及以上极数电机。

2.4 径向力校核

实际作用点不在输出轴轴伸中间时，需要下述公式对选型表中的许用径向力值进行计算。

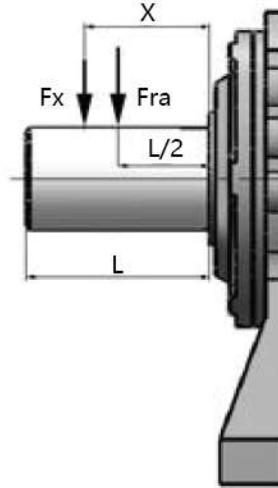

$$\text{当 } 0 \leq X < L/2 \text{ 时} \quad F_x = [1.25 - (X/2L)] \times F_{ra} \quad [\text{N}]$$

$$\text{当 } X = L/2 \text{ 时} \quad F_x = F_{ra} \quad [\text{N}]$$

$$\text{当 } L/2 < X \leq L \text{ 时} \quad F_x = [1.6 - (1.2X/L)] \times F_{ra} \quad [\text{N}]$$

F_{ra} — 选型表中给出的许用载荷（作用在 $X=L/2$ 处）

F_x — 实际作用点的许用径向载荷

X — 样本中轴肩到载荷实际作用点的距离

L — 输出轴轴伸长度（本样本中给定的长度，参照外形安装尺寸图表）

工作元件的实际径向载荷 F_r 与实际工况系数 f_A 的乘积不得大于实际作用点的许用径向载荷 F_x ，即 $f_A \times F_r \leq F_x$

2.5 选型参数表注释

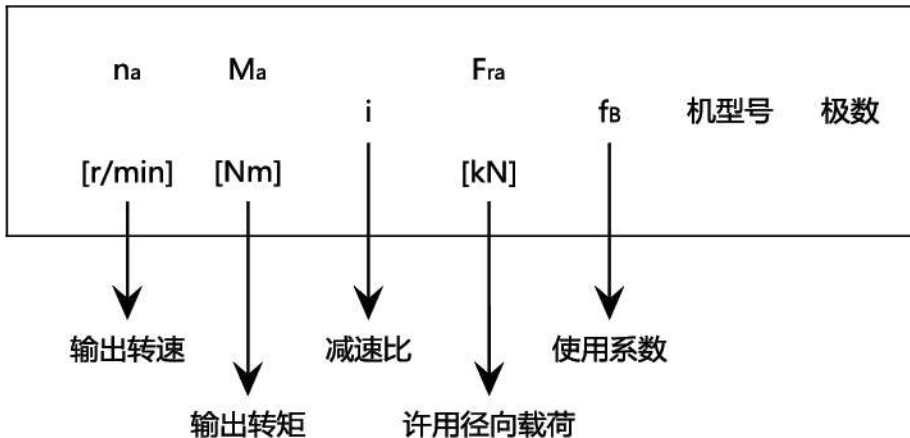

2.6 选型参数表

n _a [r/min]	M _a [Nm]	i	F _{ra}	f _b	机型号	极数	n _a [r/min]	M _a [Nm]	i	F _{ra}	f _b	机型号	极数		
			[kN]							[kN]					
0.18kW			频率	Hz	50		0.18kW			频率	Hz	50			
			极数	P	4	6				极数	P	4	6		
			转速 n	r/min	1315	850				转速 n	r/min	1315	850		
0.26	600	5133	8.0	O	B20 X42	4P	30.6	51	43	1.2	1.35	B09 X1	4P		
0.31	600	4189	8.0	O			37.6	41	35	1.2	1.85				
0.38	600	3481	8.0	O			45.3	34	29	1.2	1.85				
0.43	600	3053	8.0	O			57.2	27	23	1.0	1.85				
0.52	600	2537	8.0	O			77.4	20	17	1.0	2.75				
0.64	600	2065	8.0	O			87.7	18	15	1.0	2.75				
0.71	600	1849	8.0	O			101.2	15	13	0.8	2.75				
0.81	600	1633	8.0	O			119.5	13	11	0.8	2.75				
0.87	600	1505	8.0	O			0.25kW			频率	Hz			50	
0.97	600	1357	8.0	O						极数	P			4	6
1.1	600	1225	8.0	O						转速 n	r/min	1340	855		
1.3	600	1003	8.0	O			0.22	2500	6177	15.7	O	B41 X63	4P		
1.6	600	841	8.0	O			0.26	2500	5133	15.7	O				
1.8	600	731	8.0	O			0.32	2500	4189	15.7	O				
2.0	600	649	8.0	O			0.38	2500	3481	15.7	O				
2.2	583	595	8.0	1.00			0.44	2500	3053	15.7	O				
2.7	483	493	8.0	1.20			0.53	2500	2537	15.7	O				
3.4	383	391	8.0	1.55			0.65	2500	2065	15.7	O				
4.1	313	319	8.0	1.90			0.72	2489	1849	15.7	1.00				
4.6	283	289	8.0	2.10			0.82	2199	1633	15.7	1.10				
5.2	248	253	8.0	2.40	0.89	2026	1505	15.7	1.20						
7.0	183	187	8.0	3.25	1.0	1813	1357	15.7	1.35						
8.0	162	165	8.0	3.65	1.1	1637	1225	15.7	1.50						
9.2	140	143	8.0	3.75	1.3	1340	1003	15.7	1.85						
10.9	119	121	8.0	3.75	1.6	1124	841	15.7	2.20						
0.31	240	4189	5.2	O	1.8	977	731	15.7	2.50						
0.38	240	3481	5.2	O	2.1	867	649	15.7	2.85						
0.43	240	3053	5.2	O	2.3	795	595	15.7	3.10						
0.52	240	2537	5.2	O	2.7	659	493	15.7	3.75						
0.64	240	2065	5.2	O	0.22	1250	6177	11.6	O						
0.71	240	1849	5.2	O	0.26	1250	5133	11.6	O						
0.81	240	1633	5.2	O	0.32	1250	4189	11.6	O						
0.87	240	1505	5.2	O	0.38	1250	3481	11.6	O						
1.0	240	1357	5.2	O	0.44	1250	3053	11.6	O						
1.1	240	1225	5.2	O	0.53	1250	2537	11.6	O						
1.3	240	1003	5.2	O	0.65	1250	2065	11.6	O						
1.6	240	841	5.2	O	0.72	1250	1849	11.6	O						
1.8	240	731	5.2	O	0.82	1250	1633	11.6	O						
2.0	240	649	5.2	O	0.89	1250	1505	11.6	O						
2.2	240	595	5.2	O	1.0	1250	1357	11.6	O						
2.7	240	493	5.2	O	1.1	1250	1225	11.6	O						
3.4	240	391	5.2	O	1.3	1250	1003	11.6	O						
4.1	240	319	5.2	O	1.6	1124	841	11.6	1.10						
4.6	240	289	5.2	O	1.8	977	731	11.6	1.25						
5.2	240	253	5.2	O	2.1	867	649	11.6	1.40						
7.0	183	187	5.2	1.30	2.3	795	595	11.6	1.55						
8.0	162	165	5.2	1.45	2.7	659	493	11.6	1.85						
9.2	140	143	5.2	1.70	3.4	522	391	11.6	2.35						
10.9	119	121	5.2	1.95	4.2	426	319	11.6	2.90						
13.3	97	99	5.2	2.40	4.6	386	289	11.6	3.20						
22.3	69	59	3.0	1.85	5.3	338	253	11.6	3.65						
30.6	51	43	3.0	2.75	0.26	600	5133	8.0	O						
37.6	41	35	2.9	2.75	0.32	600	4189	8.0	O						
45.3	34	29	2.9	4.10	0.38	600	3481	8.0	O						
57.2	27	23	2.4	4.10	0.44	600	3053	8.0	O						

注：1. 带*机型不能配置直联电机；

2. f_b栏有“O”的机型，不能使用电机100%功率，运转时负载转矩请保持在表中“M_a”以下，为了保护主机，请自加安全装置；

3. 所有机型均可配置对应相同电机机座号的6P、8P电机；

4. 三级传动许用输出扭矩、许用径向力值参照二级传动中的最大值。

选型参数表

n _a [r/min]	M _a [Nm]	i	F _{ra}	f _b	机型号	极数	n _a	M _a	i	F _{ra}	f _b	机型号	极数
			[kN]				[r/min]	[Nm]		[kN]			
0.25kW			频率	Hz	50		0.25kW			频率	Hz	50	
			极数	P	4	6				极数	P	4	6
			转速 n	r/min	1340	855				转速 n	r/min	1340	855
0.53	600	2537	8.0	O	B20 X42	4P	31.2	69	43	1.2	0.95	B09 X1	4P
0.65	600	2065	8.0	O			38.3	56	35	1.2	1.35		
0.72	600	1849	8.0	O			46.2	47	29	1.2	1.35		
0.82	600	1633	8.0	O			58.3	37	23	1.0	1.35		
0.89	600	1505	8.0	O			78.8	27	17	1.0	1.95		
1.0	600	1357	8.0	O			89.3	24	15	1.0	1.95		
1.1	600	1225	8.0	O			103.1	21	13	0.8	1.95		
1.3	600	1003	8.0	O			121.8	18	11	0.8	1.95		
1.6	600	841	8.0	O			148.9	14	9	0.8	2.60		
1.8	600	731	8.0	O			0.37kW			频率	Hz		
2.1	600	649	8.0	O						极数	P	4	6
2.3	600	595	8.0	O						转速 n	r/min	1340	885
2.7	600	493	8.0	O			0.22	2500	6177	15.7	O	B41 X63	4P
3.4	522	391	8.0	1.10			0.26	2500	5133	15.7	O		
4.2	426	319	8.0	1.35			0.32	2500	4189	15.7	O		
4.6	386	289	8.0	1.50			0.38	2500	3481	15.7	O		
5.3	338	253	8.0	1.75			0.44	2500	3053	15.7	O		
7.2	250	187	8.0	2.35			0.53	2500	2537	15.7	O		
8.1	220	165	8.0	2.70			0.65	2500	2065	15.7	O		
9.4	191	143	8.0	3.10			0.72	2500	1849	15.7	O		
11.1	162	121	8.0	3.65	0.82	2500	1633	15.7	O				
0.32	240	4189	5.2	O	0.89	2500	1505	15.7	O				
0.38	240	3481	5.2	O	0.99	2500	1357	15.7	O				
0.44	240	3053	5.2	O	1.1	2500	1225	15.7	O				
0.53	240	2537	5.2	O	1.3	1984	1003	15.7	1.00				
0.65	240	2065	5.2	O	1.6	1663	841	15.7	1.20				
0.72	240	1849	5.2	O	1.8	1446	731	15.7	1.40				
0.82	240	1633	5.2	O	2.1	1284	649	15.7	1.60				
0.89	240	1505	5.2	O	2.3	1177	595	15.7	1.75				
1.0	240	1357	5.2	O	2.7	975	493	15.7	2.10				
1.1	240	1225	5.2	O	3.4	773	391	15.7	2.65				
1.3	240	1003	5.2	O	4.2	631	319	15.7	3.25				
1.6	240	841	5.2	O	4.6	572	289	15.7	3.60				
1.8	240	731	5.2	O	0.22	1250	6177	11.6	O	B31 X53	4P		
2.1	240	649	5.2	O	0.26	1250	5133	11.6	O				
2.3	240	595	5.2	O	0.32	1250	4189	11.6	O				
2.7	240	493	5.2	O	0.38	1250	3481	11.6	O				
3.4	240	391	5.2	O	0.44	1250	3053	11.6	O				
4.2	240	319	5.2	O	0.53	1250	2537	11.6	O				
4.6	240	289	5.2	O	0.65	1250	2065	11.6	O				
5.3	240	253	5.2	O	0.72	1250	1849	11.6	O				
7.2	240	187	5.2	O	0.82	1250	1633	11.6	O				
8.1	220	165	5.2	1.05	0.89	1250	1505	11.6	O				
9.4	191	143	5.2	1.20	1.0	1250	1357	11.6	O				
11.1	162	121	5.2	1.45	1.1	1250	1225	11.6	O				
13.5	132	99	5.2	1.80	1.3	1250	1003	11.6	O				
18.9	114	71	5.2	2.05	1.6	1250	841	11.6	O				
22.7	95	59	4.8	2.50	1.8	1250	731	11.6	O				
28.5	75	47	4.4	3.15	2.1	1250	649	11.6	O				
31.2	69	43	4.3	3.45	2.3	1177	595	11.6	1.05				
22.7	95	59	3.0	1.35	2.7	975	493	11.6	1.25				
31.2	69	43	3.0	2.00	3.4	773	391	11.6	1.60				
38.3	56	35	2.9	2.00	4.2	631	319	11.6	1.95				
46.2	47	29	2.9	2.95	4.6	572	289	11.6	2.15				
58.3	37	23	2.4	2.95	5.3	500	253	11.6	2.45				

- 注：1. 带*机型不能配置直联电机；
 2. f_b栏有“O”的机型，不能使用电机100%功率，运转时负载转矩请保持在表中“Ma”以下，为了保护主机，请自加安全装置；
 3. 所有机型均可配置对应相同电机机座号的6P、8P电机；
 4. 三级传动许用输出扭矩、许用径向力值参照二级传动中的最大值。

选型参数表

n _a [r/min]	M _a [Nm]	i	F _{ra}	f _b	机型号	极数	n _a [r/min]	M _a [Nm]	i	F _{ra}	f _b	机型号	极数
			[kN]	Hz						[kN]	Hz		
0.37kW			频率	Hz	50		0.55kW			频率	Hz	50	
			极数	P	4	6				极数	P	4	6
			转速 n	r/min	1340	885				转速 n	r/min	1390	885
7.2	370	187	11.6	3.35	B31	4P	0.67	5000	2065	33.1	O	B52 X84	4P
8.1	326	165	11.6	3.60	X53		0.75	5000	1849	33.1	O		
2.1	600	649	8.0	O	B20 X42	4P	0.85	4628	1633	33.1	1.05		
2.3	600	595	8.0	O			0.92	4265	1505	33.1	1.15		
2.7	600	493	8.0	O			1.0	3846	1357	33.1	1.30		
3.4	600	391	8.0	O			1.1	3472	1225	33.1	1.40		
4.2	600	319	8.0	O			1.4	2843	1003	33.1	1.75		
4.6	572	289	8.0	1.00			1.7	2383	841	33.1	2.05		
5.3	500	253	8.0	1.15			1.9	2072	731	33.1	2.40		
7.2	370	187	8.0	1.60			2.1	1839	649	33.1	2.70		
8.1	326	165	8.0	1.80			2.3	1686	595	33.1	2.95		
9.4	283	143	8.0	2.10			2.8	1397	493	33.1	3.55		
11.1	239	121	8.0	2.45	0.18	2500	7569	15.7	O	B42/X64/X74	4P		
13.5	196	99	8.0	2.70	0.75	2500	1849	15.7	O	B41 X63	4P		
5.3	240	253	5.2	O	0.85	2500	1633	15.7	O				
7.2	240	187	5.2	O	0.92	2500	1505	15.7	O				
8.1	240	165	5.2	O	1.0	2500	1357	15.7	O				
9.4	240	143	5.2	O	1.1	2500	1225	15.7	O				
11.1	240	121	5.2	O	1.4	2500	1003	15.7	O				
13.5	196	99	5.2	1.20	1.7	2383	841	15.7	1.00				
18.9	169	71	5.2	1.40	1.9	2072	731	15.7	1.20				
22.7	140	59	4.8	1.70	2.1	1839	649	15.7	1.35				
28.5	112	47	4.4	2.10	2.3	1686	595	15.7	1.45				
31.2	102	43	4.3	2.30	2.8	1397	493	15.7	1.75				
38.3	83	35	3.8	2.85	3.6	1108	391	15.7	2.25				
46.2	69	29	3.2	3.45	4.4	904	319	15.7	2.75				
22.7	140	59	3.0	0.90	4.8	819	289	15.7	3.05				
31.2	102	43	3.0	1.35	5.5	717	253	15.7	3.45				
38.3	83	35	2.9	1.35	1.4	1250	1003	11.6	O	B31 X53	4P		
46.2	69	29	2.9	2.00	1.7	1250	841	11.6	O				
58.3	55	23	2.4	2.00	1.9	1250	731	11.6	O				
78.8	40	17	2.3	2.70	2.1	1250	649	11.6	O				
89.3	36	15	2.2	2.70	2.3	1250	595	11.6	O				
103.1	31	13	2.0	2.70	2.8	1250	493	11.6	O				
121.8	26	11	1.9	2.70	3.6	1108	391	11.6	1.10				
148.9	21	9	1.9	2.70	4.4	904	319	11.6	1.35				
191.4	17	7	1.5	2.70	4.8	819	289	11.6	1.50				
38.3	83	35	1.2	0.90	5.5	717	253	11.6	1.70				
46.2	69	29	1.2	0.90	7.4	530	187	11.6	2.35				
58.3	55	23	1.0	0.90	8.4	468	165	11.6	2.65				
78.8	40	17	1.0	1.35	9.7	405	143	11.6	3.05				
89.3	36	15	1.0	1.35	11.5	343	121	11.6	3.60				
103.1	31	13	0.8	1.35	3.6	600	391	8.0	O	B20 X42	4P		
121.8	26	11	0.8	1.35	4.4	600	319	8.0	O				
148.9	21	9	0.8	2.00	4.8	600	289	8.0	O				
5.5	600	7569	33.1	O	5.5	600	253	8.0	O				
7.4	530	187	8.0	1.10	7.4	530	187	8.0	1.10				
8.4	468	165	8.0	1.25	8.4	468	165	8.0	1.25				
0.18	5000	7569	33.1	O	9.7	405	143	8.0	1.45				
0.23	5000	6177	33.1	O	11.5	343	121	8.0	1.70				
0.27	5000	5133	33.1	O	14.0	281	99	8.0	1.80				
0.33	5000	4189	33.1	O	8.4	240	165	5.2	O	B10 X32	4P		
0.40	5000	3481	33.1	O	9.7	240	143	5.2	O				
0.46	5000	3053	33.1	O	11.5	240	121	5.2	O				
0.55	5000	2537	33.1	O	14.0	240	99	5.2	O				

注：1. 带*机型不能配置直联电机；

2. f_b栏有“O”的机型，不能使用电机100%功率，运转时负载转矩请保持在表中“M_a”以下，为了保护主机，请自加安全装置；

3. 所有机型均可配置对应相同电机机座号的6P、8P电机；

4. 三级传动许用输出扭矩、许用径向力值参照二级传动中的最大值。

选型参数表

n _a [r/min]	M _a [Nm]	i	F _{ra}		f _s	机型号	极数	n _a [r/min]	M _a [Nm]	i	F _{ra}		f _s	机型号	极数				
			[kN]	Hz							[kN]	Hz							
0.55kW			频率	Hz	50		0.75kW			频率	Hz	50							
			极数	P	4	6				极数	P	4	6						
			转速 n	r/min	1390	885				转速 n	r/min	1385	910						
16.0	247	87	11.6	3.65	B3*	4P	0.33	5000	4189	33.1	O	B52 X84	4P						
19.6	201	71	11.6	3.65	X5*		0.40	5000	3481	33.1	O								
16.0	296	87	8.0	1.80	B2 X4	4P	0.45	5000	3053	33.1	O								
19.6	241	71	8.0	1.80					0.55	5000	2537			33.1	O				
23.6	201	59	7.4	2.70					0.67	5000	2065			33.1	O				
29.6	160	47	6.8	3.65					0.75	5000	1849			33.1	O				
32.3	146	43	6.7	3.65					0.85	5000	1633			33.1	O				
39.7	119	35	6.0	3.65					0.92	5000	1505			33.1	O				
19.6	241	71	5.2	0.90	B1 X3	4P	1.0	5000	1357	33.1	O			B41 X63	4P				
23.6	201	59	4.8	1.25					1.1	4751	1225					33.1	1.05		
29.6	160	47	4.4	1.50					1.4	3890	1003	33.1	1.25						
32.3	146	43	4.3	1.60					1.6	3262	841	33.1	1.50						
39.7	119	35	3.8	2.00					1.9	2835	731	33.1	1.75						
47.9	99	29	3.8	2.40					2.1	2517	649	33.1	1.95						
60.4	78	23	3.2	3.05					2.3	2308	595	33.1	2.15						
81.8	58	17	3.0	3.65					2.8	1912	493	33.1	2.60						
92.7	51	15	2.9	3.65					3.5	1517	391	33.1	3.30						
106.9	44	13	2.8	3.65					1.0	2500	1357	15.7	O						
32.3	146	43	3.0	0.90	B0 X2	4P	1.1	2500	1225	15.7	O	B31 X53	4P						
39.7	119	35	2.9	0.90					1.4	2500	1003			15.7	O				
47.9	99	29	2.9	1.35					1.6	2500	841			15.7	O				
60.4	78	23	2.4	1.35					1.9	2500	731			15.7	O				
81.8	58	17	2.3	1.80					2.1	2500	649			15.7	O				
92.7	51	15	2.2	1.80					2.3	2308	595			15.7	1.05				
106.9	44	13	2.0	1.80					2.8	1912	493			15.7	1.30				
126.4	37	11	1.9	1.80					3.5	1517	391			15.7	1.65				
154.4	31	9	1.9	1.80					4.3	1237	319			15.7	2.00				
198.6	24	7	1.8	1.80					4.8	1121	289			15.7	2.20				
81.8	58	17	1.0	0.90	B09 X1	4P	5.5	981	253	15.7	2.55	B20 X42	4P						
92.7	51	15	1.0	0.90					7.4	725	187			15.7	3.45				
106.9	44	13	0.8	0.90					2.1	1250	649			11.6	O				
126.4	37	11	0.8	0.90					2.3	1250	595			11.6	O				
154.4	31	9	0.8	1.20					2.8	1250	493			11.6	O				
									3.5	1250	391			11.6	O				
0.75kW			频率	Hz	50		4.3	1237	319	11.6	1.00	B10 X32	4P						
			极数	P	4	6	4.8	1121	289	11.6	1.10								
			转速 n	r/min	1385	910	4.8	1121	289	11.6	1.10								
0.18	8800	7569	52.9	O	B63* X95*	4P	5.5	981	253	11.6	1.25								
0.22	8800	6177	52.9	O					7.4	725	187			11.6	1.70				
0.27	8800	5133	52.9	O					8.4	640	165			11.6	1.95				
0.33	8800	4189	52.9	O					9.7	555	143			11.6	2.25				
0.40	8800	3481	52.9	O					11.4	469	121			11.6	2.65				
0.45	8800	3053	52.9	O					14.0	384	99			11.6	3.25				
0.55	8800	2537	52.9	O					4.8	600	289			8.0	O				
0.67	8009	2065	52.9	1.10					5.5	600	253	8.0	O						
0.75	7172	1849	52.9	1.20					7.4	600	187	8.0	O						
0.85	6334	1633	52.9	1.35					8.4	600	165	8.0	O						
0.92	5837	1505	52.9	1.50			9.7	555	143	8.0	1.05								
1.0	5263	1357	52.9	1.65			11.4	469	121	8.0	1.25								
1.1	4751	1225	52.9	1.85			14.0	384	99	8.0	1.35								
1.4	3890	1003	52.9	2.25			11.4	240	121	8.0	O	B10 X32	4P						
1.6	3262	841	52.9	2.70			14.0	240	99	8.0	O								
1.9	2835	731	52.9	3.10			15.9	405	87	11.6	2.70								
0.18	5000	7569	33.1	O	B52 X84	4P	19.5	330	71	11.6	2.70	B3* X5*	4P						
0.22	5000	6177	33.1	O					23.5	275	59			10.8	3.70				
0.27	5000	5133	33.1	O															

- 注: 1. 带*机型不能配置直联电机;
 2. f_s栏有“O”的机型, 不能使用电机 100%功率, 运转时负载转矩请保持在表中“Ma”以下, 为了保护主机, 请自加安全装置;
 3. 所有机型均可配置对应相同电机机座号的 6P、8P 电机;
 4. 三级传动许用输出扭矩、许用径向力值参照二级传动中的最大值。

选型参数表

n _a [r/min]	M _a [Nm]	i	F _{ra}	f _b	机型号	极数	n _a [r/min]	M _a [Nm]	i	F _{ra}	f _b	机型号	极数
			[kN]							[kN]			
0.75kW			频率	Hz	50		1.1kW			频率	Hz	50	
			极数	P	4	6				极数	P	4	6
			转速 n	r/min	1385	910				转速 n	r/min	1390	910
15.9	405	87	8.0	1.35	B2 X4	4P	1.4	5000	1003	33.1	O	B52 X84	4P
19.5	330	71	8.0	1.35			1.7	4767	841	33.1	1.05		
23.5	275	59	7.4	1.95			1.9	4143	731	33.1	1.20		
29.5	219	47	6.8	2.70			2.1	3679	649	33.1	1.35		
32.2	200	43	6.7	2.70			2.3	3373	595	33.1	1.45		
39.6	163	35	6.0	2.70			2.8	2794	493	33.1	1.80		
47.8	135	29	6.0	3.95	B1 X3	4P	3.6	2216	391	33.1	2.25	B41 X63	4P
23.5	275	59	4.8	0.85			4.4	1808	319	33.1	2.75		
29.5	219	47	4.4	1.10			4.8	1638	289	33.1	3.05		
32.2	200	43	4.3	1.20			5.5	1434	253	33.1	3.50		
39.6	163	35	3.8	1.45			1.7	2500	841	15.7	O		
47.8	135	29	3.8	1.75			1.9	2500	731	15.7	O		
60.2	107	23	3.2	2.25			2.1	2500	649	15.7	O		
81.5	79	17	3.0	2.70			2.3	2500	595	15.7	O		
92.3	70	15	2.9	2.70			2.8	2500	493	15.7	O		
106.5	61	13	2.8	2.70			3.6	2216	391	15.7	1.10		
125.9	51	11	2.6	3.95			4.4	1808	319	15.7	1.35		
153.9	42	9	2.6	3.95			4.8	1638	289	15.7	1.50		
197.9	33	7	2.5	3.95	5.5	1434	253	15.7	1.75				
47.8	135	29	2.9	0.95	7.4	1060	187	15.7	2.35	B31 X53	4P		
60.2	107	23	2.4	0.95	8.4	935	165	15.7	2.65				
81.5	79	17	2.3	1.35	9.7	811	143	15.7	2.70				
92.3	70	15	2.2	1.35	11.5	686	121	15.7	2.70				
106.5	61	13	2.0	1.35	14.0	561	99	15.7	2.70				
125.9	51	11	1.9	1.35	2.8	1250	493	11.6	O				
153.9	42	9	1.9	1.35	3.6	1250	391	11.6	O				
197.9	33	7	1.8	1.35	4.4	1250	319	11.6	O				
153.9	42	9	0.8	0.85	4.8	1250	289	11.6	O				
1.1kW			频率	Hz	50		5.5	1250	253			11.6	O
			极数	P	4	6	7.4	1060	187			11.6	1.15
			转速 n	r/min	1390	910	8.4	935	165			11.6	1.30
0.18	8800	7569	52.9	O	B63 X95	4P	9.7	811	143	11.6	1.55	B20* X42*	4P
0.23	8800	6177	52.9	O			11.5	686	121	11.6	1.80		
0.27	8800	5133	52.9	O			14.0	561	99	11.6	2.20		
0.33	8800	4189	52.9	O			7.4	600	187	8.0	O		
0.40	8800	3481	52.9	O			8.4	600	165	8.0	O		
0.46	8800	3053	52.9	O			9.7	600	143	8.0	O		
0.55	8800	2537	52.9	O			11.5	600	121	8.0	O		
0.67	8800	2065	52.9	O			14.0	561	99	8.0	1.05		
0.75	8800	1849	52.9	O			16.0	592	87	11.6	1.80		
0.85	8800	1633	52.9	O			19.6	483	71	11.6	1.80		
0.92	8531	1505	52.9	1.00			23.6	401	59	10.8	2.50		
1.0	7692	1357	52.9	1.15			29.6	320	47	9.8	3.65		
1.1	6944	1225	52.9	1.25			32.3	292	43	9.6	3.65		
1.4	5685	1003	52.9	1.55			16.0	592	87	8.0	0.90		
1.7	4767	841	52.9	1.85			19.6	483	71	8.0	0.90		
1.9	4143	731	52.9	2.10			23.6	401	59	7.4	1.35		
2.1	3679	649	52.9	2.40			29.6	320	47	6.8	1.80		
2.3	3373	595	52.9	2.60			32.3	292	43	6.7	1.80		
2.8	2794	493	52.9	3.15	39.7	238	35	6.0	1.80				
0.67	5000	2065	33.1	O	B52 X84	4P	47.9	197	29	6.0	2.70	B2 X4	4P
0.75	5000	1849	33.1	O			60.4	156	23	5.0	3.65		
0.85	5000	1633	33.1	O			81.8	116	17	4.8	3.80		
0.92	5000	1505	33.1	O			92.7	102	15	4.7	4.30		
1.0	5000	1357	33.1	O			106.9	88	13	4.6	4.90		
1.1	5000	1225	33.1	O									

- 注：1. 带*机型不能配置直联电机；
2. f_b栏有“O”的机型，不能使用电机100%功率，运转时负载转矩请保持在表中“M_a”以下，为了保护主机，请自加安全装置；
3. 所有机型均可配置对应相同电机机座号的6P、8P电机；
4. 三级传动许用输出扭矩、许用径向力值参照二级传动中的最大值。

选型参数表

n _a	M _a	i	F _{ra}	f _b	机型号	极数	n _a	M _a	i	F _{ra}	f _b	机型号	极数
[r/min]	[Nm]		[kN]	Hz			[r/min]	[Nm]		[kN]	Hz		
1.1kW			频率	Hz	50		1.5kW			频率	Hz	50	
			极数	P	4	6				极数	P	4	6
			转速 n	r/min	1390	910				转速 n	r/min	1390	920
32.3	292	43	4.3	0.80	B1 X3	4P	9.7	1105	143	15.7	1.95	B41 X63	4P
39.7	238	35	3.8	1.00			11.5	935	121	15.7	1.95		
47.9	197	29	3.8	1.20			14.0	765	99	15.7	1.95		
60.4	156	23	3.2	1.50			4.4	1250	319	11.6	O	B31 X53	4P
81.8	116	17	3.0	1.80			4.8	1250	289	11.6	O		
92.7	102	15	2.9	1.80			5.5	1250	253	11.6	O		
106.9	88	13	2.8	1.80			7.4	1250	187	11.6	O		
126.4	75	11	2.6	2.70			8.4	1250	165	11.6	O		
154.4	61	9	2.6	2.70			9.7	1105	143	11.6	1.10		
198.6	48	7	2.5	2.70			11.5	935	121	11.6	1.30	B3 X5	4P
81.8	116	17	2.3	0.90	14.0	765	99	11.6	1.60				
92.7	102	15	2.2	0.90	16.0	807	87	11.6	1.35				
106.9	88	13	2.0	0.90	19.6	659	71	11.6	1.35				
126.4	75	11	1.9	0.90	23.6	547	59	10.8	1.85				
154.4	61	9	1.9	0.90	29.6	436	47	9.8	2.70				
198.6	48	7	1.8	0.90	32.3	399	43	9.6	2.70	B2 X4	4P		
1.5kW			频率	Hz	50		39.7	325	35			8.5	3.60
			极数	P	4	6	23.6	547	59			7.4	0.95
			转速 n	r/min	1390	920	29.6	436	47			6.8	1.35
0.55	8800	2537	52.9	O	B63 X95	4P	32.3	399	43			6.7	1.35
0.67	8800	2065	52.9	O			39.7	325	35			6.0	1.35
0.75	8800	1849	52.9	O			47.9	269	29			6.0	1.95
0.85	8800	1633	52.9	O			60.4	213	23			5.0	2.70
0.92	8800	1505	52.9	O			81.8	158	17			4.8	3.60
1.0	8800	1357	52.9	O			92.7	139	15			4.7	3.60
1.1	8800	1225	52.9	O			106.9	121	13	4.6	3.60		
1.4	7753	1003	52.9	1.10			126.4	102	11	4.1	3.60		
1.7	6500	841	52.9	1.35			154.4	83	9	4.0	3.60		
1.9	5650	731	52.9	1.55			198.6	65	7	3.8	3.60		
2.1	5016	649	52.9	1.75	47.9	269	29	3.8	0.85	B1 X3	4P		
2.3	4599	595	52.9	1.90	60.4	213	23	3.2	1.10				
2.8	3811	493	52.9	2.30	81.8	158	17	3.0	1.35				
3.6	3022	391	52.9	2.90	92.7	139	15	2.9	1.35				
1.0	5000	1357	33.1	O	106.9	121	13	2.8	1.35				
1.1	5000	1225	33.1	O	126.4	102	11	2.6	1.95				
1.4	5000	1003	33.1	O	154.4	83	9	2.6	1.95				
1.7	5000	841	33.1	O	198.6	65	7	2.5	1.95				
1.9	5000	731	33.1	O	2.2kW			频率	Hz			50	
2.1	5016	649	33.1	1.00				极数	P			4	6
2.3	4599	595	33.1	1.05				转速 n	r/min	1410	935		
2.8	3811	493	33.1	1.30	0.19	12000	7569	72.5	O	B74 X106	4P		
3.6	3022	391	33.1	1.65	0.23	12000	6177	72.5	O				
4.4	2466	319	33.1	2.00	0.27	12000	5133	72.5	O				
4.8	2234	289	33.1	2.25	0.34	12000	4189	72.5	O				
5.5	1956	253	33.1	2.55	0.41	12000	3481	72.5	O				
7.4	1445	187	33.1	3.45	0.46	12000	3053	72.5	O				
2.3	2500	595	15.7	O	0.56	12000	2537	72.5	O				
2.8	2500	493	15.7	O	0.68	12000	2065	72.5	O				
3.6	2500	391	15.7	O	0.76	12000	1849	72.5	O				
4.4	2466	319	15.7	1.00	0.86	12000	1633	72.5	O				
4.8	2234	289	15.7	1.10	0.94	12000	1505	72.5	O				
5.5	1956	253	15.7	1.25	1.0	12000	1357	72.5	O				
7.1	1507	195	15.7	1.65	1.2	12000	1225	72.5	O				
7.4	1445	187	15.7	1.70	1.4	11209	1003	72.5	1.05				
8.4	1275	165	15.7	1.95	1.7	9399	841	72.5	1.25				

- 注：1. 带*机型不能配置直联电机；
 2. f_b栏有“O”的机型，不能使用电机 100%功率，运转时负载转矩请保持在表中“Ma”以下，为了保护主机，请自加安全装置；
 3. 所有机型均可配置对应相同电机机座号的 6P、8P 电机；
 4. 三级传动许用输出扭矩、许用径向力值参照二级传动中的最大值。

选型参数表

n _a [r/min]	M _a [Nm]	i	F _{ra}		f _B	机型号	极数	n _a [r/min]	M _a [Nm]	i	F _{ra}		f _B	机型号	极数			
			[kN]	Hz							[kN]	Hz						
2.2kW			频率	Hz	50		2.2kW				频率	Hz	50					
			极数	P	4	6					极数	P	4	6				
			转速 n	r/min	1410	935					转速 n	r/min	1410	935				
1.9	8169	731	72.5	1.45	B74 X106	4P	30.0	630	47	13.2	3.35	B4/X6/X7	4P	2.2	7253	649	72.5	1.65
2.4	6649	595	72.5	1.80			16.2	1167	87	11.6	0.90							
2.9	5510	493	72.5	2.20			19.9	952	71	11.6	0.90							
0.76	8800	1849	52.9	O			23.9	791	59	10.8	1.25							
0.86	8800	1633	52.9	O	B63 X95	4P	30.0	630	47	9.8	1.80	B3 X5	4P	0.94	8800	1505	52.9	O
1.0	8800	1357	52.9	O			32.8	577	43	9.6	1.80							
1.2	8800	1225	52.9	O			40.3	469	35	8.5	2.45							
1.4	8800	1003	52.9	O			48.6	389	29	8.5	3.00							
1.7	8800	841	52.9	O			61.3	308	23	7.3	3.35							
1.9	8169	731	52.9	1.05			74.2	255	19	7.2	4.40							
2.2	7253	649	52.9	1.20			30.0	630	47	6.8	0.90							
2.4	6649	595	52.9	1.30			32.8	577	43	6.7	0.90							
2.9	5510	493	52.9	1.60			40.3	469	35	6.0	0.90							
3.6	4370	391	52.9	2.00			48.6	389	29	6.0	1.35							
4.4	3565	319	52.9	2.50	61.3	308	23	5.0	1.80									
4.9	3230	289	52.9	2.75	82.9	228	17	4.8	2.45									
5.6	2827	253	52.9	3.15	94.0	201	15	4.7	2.45									
1.4	5000	1003	33.1	O	108.5	174	13	4.6	2.45									
1.7	5000	841	33.1	O	128.2	148	11	4.1	2.45									
1.9	5000	731	33.1	O	156.7	121	9	4.0	2.45									
2.2	5000	649	33.1	O	201.4	94	7	3.8	2.45									
2.4	5000	595	33.1	O	82.9	228	17	3.0	0.90									
2.9	5000	493	33.1	O	94.0	201	15	2.9	0.90									
3.6	4370	391	33.1	1.15	108.5	174	13	2.8	0.90									
4.4	3565	319	33.1	1.40	128.2	148	11	2.6	1.35									
4.9	3230	289	33.1	1.55	156.7	121	9	2.6	1.35									
5.6	2827	253	33.1	1.75	201.4	94	7	2.5	1.35									
8.5	1844	165	33.1	2.45			3kW		频率	Hz	50							
9.9	1598	143	33.1	2.45					极数	P	4	6						
11.7	1352	121	33.1	2.45					转速 n	r/min	1410	965						
14.2	1106	99	33.1	2.45					0.19	21500	7569	91.7	O	B84 X117	4P			
8.5	1844	165	15.7	1.35	B42 X74 X64	4P	0.23	21500	6177	91.7	O							
9.9	1598	143	15.7	1.55			0.27	21500	5133	91.7	O							
11.7	1352	121	15.7	1.85			0.34	21500	4189	91.7	O							
14.2	1106	99	15.7	2.25			0.41	21500	3481	91.7	O							
3.6	2500	391	15.7	O	0.46	21500	3053	91.7	O									
4.4	2500	319	15.7	O	0.56	21500	2537	91.7	O									
4.9	2500	289	15.7	O	0.68	21500	2065	91.7	O									
5.6	2500	253	15.7	O	0.76	21500	1849	91.7	O									
7.5	2090	187	15.7	1.20	0.86	21500	1633	91.7	O									
8.5	1844	165	15.7	1.35	0.94	21500	1505	91.7	O									
9.9	1598	143	15.7	1.35	1.0	20680	1357	91.7	1.05									
11.7	1352	121	15.7	1.35	1.2	18668	1225	91.7	1.15									
14.2	1106	99	15.7	1.35	1.4	15285	1003	91.7	1.40									
7.5	1250	187	11.6	O	1.7	12816	841	91.7	1.70									
8.5	1250	165	11.6	O	1.9	11140	731	91.7	1.95									
9.9	1250	143	11.6	O	2.2	9890	649	91.7	2.20									
11.7	1250	121	11.6	O	2.4	9067	595	91.7	2.40									
14.2	1106	99	11.6	1.15	2.9	7513	493	91.7	2.90									
16.2	1167	87	15.7	1.80	0.19	12000	7569	72.5	O									
19.9	952	71	15.7	1.80	0.23	12000	6177	72.5	O									
23.9	791	59	14.5	2.45	0.27	12000	5133	72.5	O									
					0.34	12000	4189	72.5	O									
					0.41	12000	3481	72.5	O									

注：1. 带*机型不能配置直联电机；

2. f_B栏有“O”的机型，不能使用电机100%功率，运转时负载转矩请保持在表中“Ma”以下，为了保护主机，请自加安全装置；

3. 所有机型均可配置对应相同电机机座号的6P、8P电机；

4. 三级传动许用输出扭矩、许用径向力值参照二级传动中的最大值。

选型参数表

n _a [r/min]	M _a [Nm]	i	F _{ra}	f _B	机型号	极数	n _a	M _a	i	F _{ra}	f _B	机型号	极数		
			[kN]				[r/min]	[Nm]		[kN]					
3kW			频率	Hz	50		3kW			频率	Hz	50			
			极数	P	4	6				极数	P	4	6		
			转速 n	r/min	1410	965				转速 n	r/min	1410	965		
0.46	12000	3053	72.5	O	B74 X106	4P	16.2	1591	87	33.1	2.45	B5* X8*	4P		
0.56	12000	2537	72.5	O			19.9	1298	71	30.2	3.10				
0.68	12000	2065	72.5	O			23.9	1079	59	28.1	3.35				
0.76	12000	1849	72.5	O			16.2	1591	87	15.7	1.35	B4 X6 X7	4P		
0.86	12000	1633	72.5	O			19.9	1298	71	15.7	1.35				
0.94	12000	1505	72.5	O			23.9	1079	59	14.5	1.80				
1.0	12000	1357	72.5	O			30.0	860	47	13.2	2.45				
1.2	12000	1225	72.5	O			32.8	786	43	13.0	2.45				
1.4	12000	1003	72.5	O			40.3	640	35	11.5	3.35				
1.7	12000	841	72.5	O			48.6	530	29	11.5	3.35				
1.9	11140	731	72.5	1.05			23.9	1079	59	10.8	0.90	B3 X5	4P		
2.2	9890	649	72.5	1.20			30.0	860	47	9.8	1.35				
2.4	9067	595	72.5	1.30			32.8	786	43	9.6	1.35				
2.9	7513	493	72.5	1.60			40.3	640	35	8.5	1.80				
3.6	5959	391	72.5	2.00			48.6	530	29	8.5	2.00				
4.4	4861	319	72.5	2.50			61.3	421	23	7.3	2.45				
4.9	4404	289	72.5	2.75			74.2	347	19	7.2	3.25				
1.2	8800	1225	52.9	O			B63 X95	4P	82.9	311	17	6.7	3.25	B2 X4	4P
1.4	8800	1003	52.9	O					94.0	274	15	6.5	3.25		
1.7	8800	841	52.9	O	108.5	238			13	6.2	3.35				
1.9	8800	731	52.9	O	128.2	201			11	5.9	3.35				
2.2	8800	649	52.9	O	156.7	165			9	5.5	3.35				
2.4	8800	595	52.9	O	48.6	530			29	6.0	0.95				
2.9	7513	493	52.9	1.15	61.3	421			23	5.0	1.35				
3.6	5959	391	52.9	1.45	82.9	311			17	4.8	1.80				
4.4	4861	319	52.9	1.80	94.0	274			15	4.7	1.80				
4.9	4404	289	52.9	2.00	108.5	238			13	4.6	1.80				
5.6	3856	253	52.9	2.30	128.2	201			11	4.1	1.80				
7.5	2850	187	52.9	3.10	156.7	165			9	4.0	1.80				
8.5	2514	165	52.9	3.35	201.4	128			7	3.8	1.80				
9.9	2179	143	52.9	3.35	128.2	201			11	2.6	0.95	B1* X3*	4P		
11.7	1844	121	52.9	3.35	156.7	165			9	2.6	0.95				
14.2	1509	99	52.9	3.35	201.4	128			7	2.5	0.95				
8.5	2514	165	33.1	2.00	B53 X85	4P			4kW			频率	Hz	50	
9.9	2179	143	33.1	2.30								极数	P	4	6
11.7	1844	121	33.1	2.75								转速 n	r/min	1435	965
14.2	1509	99	33.1	3.35	B52 X84	4P	0.19	21500	7569	91.7	O	B84 X117	4P		
2.4	5000	595	33.1	O			0.23	21500	6177	91.7	O				
2.9	5000	493	33.1	O			0.28	21500	5133	91.7	O				
3.6	5000	391	33.1	O			0.34	21500	4189	91.7	O				
4.4	4861	319	33.1	1.00			0.41	21500	3481	91.7	O				
4.9	4404	289	33.1	1.15			0.47	21500	3053	91.7	O				
5.6	3856	253	33.1	1.30			0.57	21500	2537	91.7	O				
7.5	2850	187	33.1	1.75			0.69	21500	2065	91.7	O				
8.5	2514	165	33.1	1.80			0.78	21500	1849	91.7	O				
9.9	2179	143	33.1	1.80			0.88	21500	1633	91.7	O				
11.7	1844	121	33.1	1.80			1.0	21500	1505	91.7	O				
14.2	1509	99	33.1	1.80			1.1	21500	1357	91.7	O				
4.4	2500	319	15.7	O			1.2	21500	1225	91.7	O			B42 X64 X74	4P
4.9	2500	289	15.7	O	1.4	20025	1003	91.7	1.05						
5.6	2500	253	15.7	O	1.7	16791	841	91.7	1.25						
7.5	2500	187	15.7	O	2.0	14595	731	91.7	1.45						
8.5	2514	165	15.7	1.00	2.2	12957	649	91.7	1.65						
9.9	2179	143	15.7	1.15	2.4	11879	595	91.7	1.80						
11.7	1844	121	15.7	1.35	2.9	9843	493	91.7	2.15						
14.2	1509	99	15.7	1.65	3.7	7806	391	91.7	2.75						

- 注：1. 带*机型不能配置直联电机；
 2. f_B栏有“O”的机型，不能使用电机 100%功率，运转时负载转矩请保持在表中“Ma”以下，为了保护主机，请自加安全装置；
 3. 所有机型均可配置对应相同电机机座号的 6P、8P 电机；
 4. 三级传动许用输出扭矩、许用径向力值参照二级传动中的最大值。

选型参数表

n _a [r/min]	M _a [Nm]	i	F _{ra}	f _β	机型号	极数	n _a [r/min]	M _a [Nm]	i	F _{ra}	f _β	机型号	极数
			[kN]	Hz						[kN]	Hz		
4kW			频率	Hz	50		4kW			频率	Hz	50	
			极数	P	4	6				极数	P	4	6
			转速 n	r/min	1435	965				转速 n	r/min	1435	965
4.5	6369	319	91.7	3.35	B84 X117	4P	16.5	2084	87	33.1	1.85	B5* X8*	4P
5.0	5770	289	91.7	3.70			20.2	1701	71	30.2	2.30		
5.7	5051	253	91.7	3.70	B74 X106	4P	24.3	1414	59	28.1	2.50	B4 X6 X7	4P
7.7	3733	187	91.7	3.70			30.5	1126	47	27.0	3.70		
1.1	12000	1357	72.5	O			33.4	1030	43	26.4	3.70		
1.2	12000	1225	72.5	O			16.5	2084	87	15.7	1.00		
1.4	12000	1003	72.5	O			20.2	1701	71	15.7	1.00		
1.7	12000	841	72.5	O			24.3	1414	59	14.5	1.35		
2.0	12000	731	72.5	O			30.5	1126	47	13.2	1.85		
2.2	12000	649	72.5	O			33.4	1030	43	13.0	1.85		
2.4	11879	595	72.5	1.00			41.0	839	35	11.5	2.50		
2.9	9843	493	72.5	1.20			49.5	695	29	11.5	2.50		
3.7	7806	391	72.5	1.50			62.4	551	23	9.8	3.70		
4.5	6369	319	72.5	1.85			30.5	1126	47	9.8	1.00		
5.0	5770	289	72.5	2.05			33.4	1030	43	9.6	1.00		
5.7	5051	253	72.5	2.35			41.0	839	35	8.5	1.35		
7.7	3733	187	72.5	3.20	49.5	695	29	8.5	1.65				
8.4	3294	165	72.5	3.50	62.4	551	23	7.3	1.85				
11.4	2416	121	72.5	3.70	75.5	455	19	7.2	2.40				
13.9	1977	99	72.5	3.70	84.4	407	17	6.7	2.40				
1.7	8800	841	52.9	O	95.7	359	15	6.5	2.40				
2.0	8800	731	52.9	O	110.4	311	13	6.2	2.50				
2.2	8800	649	52.9	O	130.5	264	11	5.9	2.50				
2.4	8800	595	52.9	O	159.4	216	9	5.5	2.50				
2.9	8800	493	52.9	O	62.4	551	23	5.0	1.00				
3.7	7806	391	52.9	1.10	84.4	407	17	4.8	1.35				
4.5	6369	319	52.9	1.35	95.7	359	15	4.7	1.35				
5.0	5770	289	52.9	1.50	110.4	311	13	4.6	1.35				
5.7	5051	253	52.9	1.70	130.5	264	11	4.1	1.35				
7.7	3733	187	52.9	2.35	159.4	216	9	4.0	1.35				
8.7	3294	165	52.9	2.50	205.0	168	7	3.8	1.35				
10.0	2855	143	52.9	2.50	5.5kW		频率	Hz	50		B3 X5	4P	
11.9	2416	121	52.9	2.50			极数	P	4	6			
14.5	1977	99	52.9	2.50			转速 n	r/min	1445	965			
7.7	3733	187	33.1	1.30	B53 X85	4P	0.19	29400	7569	158.4	O	B2 X4	4P
8.7	3294	165	33.1	1.50			0.23	29400	6177	158.4	O		
10.0	2855	143	33.1	1.75			0.28	29400	5133	158.4	O		
11.9	2416	121	33.1	2.05			0.34	29400	4189	158.4	O		
14.5	1977	99	33.1	2.50			0.42	29400	3481	158.4	O		
2.9	5000	493	33.1	O	0.47	29400	3053	158.4	O	B95 X128	4P		
3.7	5000	391	33.1	O	0.57	29400	2537	158.4	O				
4.5	5000	319	33.1	O	0.70	29400	2065	158.4	O				
5.0	5000	289	33.1	O	0.78	29400	1849	158.4	O				
5.7	5000	253	33.1	O	0.88	29400	1633	158.4	O				
7.7	3733	187	33.1	1.30	0.96	29400	1505	158.4	O				
8.7	3294	165	33.1	1.35	1.1	29400	1357	158.4	O				
10.0	2855	143	33.1	1.35	1.2	29400	1225	158.4	O				
11.9	2416	121	33.1	1.35	1.4	27344	1003	158.4	1.05				
14.5	1977	99	33.1	1.35	1.7	22927	841	158.4	1.25				
7.7	2500	187	15.7	O	2.0	19929	731	158.4	1.45			B42 X64 X74	4P
8.7	2500	165	15.7	O	2.2	17693	649	158.4	1.65				
10.0	2500	143	15.7	O	2.4	16221	595	158.4	1.80				
11.9	2416	121	15.7	1.00	2.9	13440	493	158.4	2.15				
14.5	1977	99	15.7	1.25	3.7	10659	391	158.4	2.70				

注：1. 带*机型不能配置直联电机；

2. f_β栏有“O”的机型，不能使用电机100%功率，运转时负载转矩请保持在表中“M_a”以下，为了保护主机，请自加安全装置；

3. 所有机型均可配置对应相同电机机座号的6P、8P电机；

4. 三级传动许用输出扭矩、许用径向力值参照二级传动中的最大值。

选型参数表

n _a [r/min]	M _a [Nm]	i	F _{ra}	f _B	机型号	极数	n _a	M _a	i	F _{ra}	f _B	机型号	极数		
			[kN]				[r/min]	[Nm]		[kN]					
5.5kW			频率	Hz	50		5.5kW			频率	Hz	50			
			极数	P	4	6				极数	P	4	6		
			转速 n	r/min	1445	965				转速 n	r/min	1445	965		
0.70	21500	2065	91.7	O	B84 X117	4P	11.1	4262	87	52.9	1.75	B6* X9*	6P		
0.78	21500	1849	91.7	O			13.6	3478	71	52.9	1.75				
0.88	21500	1633	91.7	O			16.4	2890	59	49.6	1.80				
1.0	21500	1505	91.7	O			20.5	2302	47	49.6	2.70				
1.1	21500	1357	91.7	O			22.4	2106	43	49.6	2.70				
1.2	21500	1225	91.7	O			16.6	2846	87	33.1	1.35				
1.4	21500	1003	91.7	O			20.4	2323	71	30.2	1.70				
1.7	21500	841	91.7	O			24.5	1930	59	28.1	1.80				
2.0	19929	731	91.7	1.05			30.7	1538	47	27.0	2.70				
2.2	17693	649	91.7	1.20			33.6	1407	43	26.4	2.70				
2.4	16221	595	91.7	1.30			41.3	1145	35	26.4	3.40				
2.9	13440	493	91.7	1.55			49.8	949	29	25.2	3.65				
3.7	10659	391	91.7	2.00			24.5	1930	59	14.5	0.95				
4.5	8697	319	91.7	2.45			30.7	1538	47	13.2	1.35				
5.0	7879	289	91.7	2.70			33.6	1407	43	13.0	1.35				
5.7	6897	253	91.7	2.70			41.3	1145	35	11.5	1.80				
7.7	5098	187	91.7	2.70			49.8	949	29	11.5	1.80				
1.4	12000	1003	72.5	O	B74 X106	4P	62.8	752	23	9.8	2.70	B4 X6 X7	4P		
1.7	12000	841	72.5	O			76.1	622	19	9.4	2.70				
2.0	12000	731	72.5	O			85.0	556	17	9.1	2.70				
2.2	12000	649	72.5	O			96.3	491	15	8.8	2.70				
2.4	12000	595	72.5	O			111.2	425	13	8.4	2.70				
2.9	12000	493	72.5	O			131.4	360	11	8.0	2.70				
3.7	10659	391	72.5	1.10			160.6	294	9	6.6	2.70				
4.5	8697	319	72.5	1.35			41.3	1145	35	8.5	0.95				
5.0	7879	289	72.5	1.50			49.8	949	29	8.5	1.20				
5.7	6897	253	72.5	1.70			62.8	752	23	7.3	1.35				
7.7	5098	187	72.5	2.30			76.1	622	19	7.2	1.75				
8.4	4498	165	72.5	2.55	85.0	556	17	6.7	1.75						
11.4	3299	121	72.5	2.70	96.3	491	15	6.5	1.75						
13.9	2699	99	72.5	2.70	111.2	425	13	6.2	1.80						
8.8	4498	165	52.9	1.95	131.4	360	11	5.9	1.80						
10.1	3898	143	52.9	2.20	160.6	294	9	5.5	1.80						
11.9	3299	121	52.9	2.65	85.0	556	17	4.8	0.95						
14.6	2699	99	52.9	2.70	96.3	491	15	4.7	0.95						
2.4	8800	595	52.9	O	B63 X95	4P	111.2	425	13	4.6	0.95	B2* X4*	4P		
2.9	8800	493	52.9	O			131.4	360	11	4.1	0.95				
3.7	8800	391	52.9	O			160.6	294	9	4.0	0.95				
4.5	8697	319	52.9	1.00			206.4	229	7	3.8	0.95				
5.0	7879	289	52.9	1.10			7.5kW			频率	Hz	50			
5.7	6897	253	52.9	1.25						极数	P	4	6		
7.7	5098	187	52.9	1.70						转速 n	r/min	1445	970		
8.8	4498	165	52.9	1.80			0.19	29400	7569	158.4	O	B95 X128	4P		
10.1	3898	143	52.9	1.80			0.23	29400	6177	158.4	O				
11.9	3299	121	52.9	1.80			0.28	29400	5133	158.4	O				
14.6	2699	99	52.9	1.80	0.34	29400	4189	158.4	O						
4.5	5000	319	33.1	O	0.42	29400	3481	158.4	O						
5.0	5000	289	33.1	O	0.47	29400	3053	158.4	O						
5.7	5000	253	33.1	O	0.57	29400	2537	158.4	O						
7.7	5000	187	33.1	O	0.70	29400	2065	158.4	O						
8.8	4498	165	33.1	1.10	0.78	29400	1849	158.4	O						
10.1	3898	143	33.1	1.25	0.88	29400	1633	158.4	O						
11.9	3299	121	33.1	1.50	0.96	29400	1505	158.4	O						
14.6	2699	99	33.1	1.80	1.1	29400	1357	158.4	O						

- 注：1. 带*机型不能配置直联电机；
 2. f_B栏有“O”的机型，不能使用电机 100%功率，运转时负载转矩请保持在表中“Ma”以下，为了保护主机，请自加安全装置；
 3. 所有机型均可配置对应相同电机机座号的 6P、8P 电机；
 4. 三级传动许用输出扭矩、许用径向力值参照二级传动中的最大值。

选型参数表

n _a [r/min]	M _a [Nm]	i	F _{ra}	f _B	机型号	极数	n _a [r/min]	M _a [Nm]	i	F _{ra}	f _B	机型号	极数
			[kN]							[kN]			
7.5kW			频率	Hz	50		7.5kW			频率	Hz	50	
			极数	P	4	6				极数	P	4	6
			转速 n	r/min	1445	970				转速 n	r/min	1445	970
1.2	29400	1225	158.4	O	B95 X128	4P	5.7	5000	253	33.1	O	B53 X85	4P
1.4	29400	1003	158.4	O			7.7	5000	187	33.1	O		
1.7	29400	841	158.4	O			8.8	5000	165	33.1	O		
2.0	27175	731	158.4	1.05			10.1	5000	143	33.1	O		
2.2	24127	649	158.4	1.20			11.9	4498	121	33.1	1.10		
2.4	22119	595	158.4	1.30			14.6	3680	99	33.1	1.35		
2.9	18328	493	158.4	1.55			11.1	5782	87	72.5	1.65		
3.7	14536	391	158.4	2.00			13.7	4718	71	72.5	2.30		
4.5	11859	319	158.4	2.45	16.4	3921	59	66.5	2.80	B7* X10*	6P		
5.7	9405	253	91.7	2.25	20.6	3123	47	63.4	3.20				
7.7	6952	187	91.7	3.05	B85 X118	4P	22.6	2858	43	62.2	3.80	B6* X9*	6P
1.1	21500	1357	91.7	O	27.7	2326	35	58.9	3.80				
1.2	21500	1225	91.7	O	11.1	5782	87	52.9	1.30				
1.4	21500	1003	91.7	O	13.7	4718	71	52.9	1.30				
1.7	21500	841	91.7	O	16.4	3921	59	49.6	1.35				
2.0	21500	731	91.7	O	20.6	3123	47	49.6	1.95				
2.2	21500	649	91.7	O	22.6	2858	43	49.6	1.95				
2.4	21500	595	91.7	O	27.7	2326	35	46.9	2.70				
2.9	18328	493	91.7	1.15	33.4	1927	29	44.8	3.20	B5 X8	4P		
3.7	14536	391	91.7	1.45	16.6	3881	87	33.1	0.95				
4.5	11859	319	91.7	1.80	20.4	3167	71	30.2	1.25				
5.0	10744	289	91.7	1.95	24.5	2632	59	28.1	1.35				
5.7	9405	253	91.7	1.95	30.7	2097	47	27.0	1.95				
7.7	6952	187	91.7	1.95	33.6	1918	43	26.4	1.95				
11.4	4498	121	91.7	1.95	41.3	1561	35	26.4	2.50				
13.9	3680	99	91.7	1.95	49.8	1294	29	25.2	2.70				
2.2	12000	649	72.5	O	62.8	1026	23	22.2	3.30	B4 X6 X7	4P		
2.4	12000	595	72.5	O	76.1	848	19	21.6	3.30				
2.9	12000	493	72.5	O	85.0	758	17	20.9	3.30				
3.7	12000	391	72.5	O	96.3	669	15	19.2	3.30				
4.5	11859	319	72.5	1.00	111.2	580	13	16.8	3.30				
5.0	10744	289	72.5	1.10	131.4	491	11	15.4	3.30				
5.7	9405	253	72.5	1.25	30.7	2097	47	13.2	0.95				
7.7	6952	187	72.5	1.70	33.6	1918	43	13.0	0.95				
8.4	6134	165	72.5	1.85	41.3	1561	35	11.5	1.35	B3 X5	4P		
11.4	4498	121	72.5	1.95	49.8	1294	29	11.5	1.35				
13.9	3680	99	72.5	1.95	62.8	1026	23	9.8	1.95				
8.8	6134	165	52.9	1.40	76.1	848	19	9.4	1.95				
10.1	5316	143	52.9	1.65	85.0	758	17	9.1	1.95				
11.9	4498	121	52.9	1.95	96.3	669	15	8.8	1.95				
14.6	3680	99	52.9	1.95	111.2	580	13	8.4	1.95				
3.7	8800	391	52.9	O	131.4	491	11	8.0	1.95				
4.5	8800	319	52.9	O	160.6	401	9	6.6	1.95				
5.0	8800	289	52.9	O	49.8	1294	29	8.5	0.85	B64 X96	4P		
5.7	8800	253	52.9	O	62.8	1026	23	7.3	0.95				
7.7	6952	187	52.9	1.25	76.1	848	19	7.2	1.30				
8.8	6134	165	52.9	1.35	85.0	758	17	6.7	1.30				
10.1	5316	143	52.9	1.35	96.3	669	15	6.5	1.30				
11.9	4498	121	52.9	1.35	111.2	580	13	6.2	1.35				
14.6	3680	99	52.9	1.35	131.4	491	11	5.9	1.35				
14.6	3680	99	52.9	1.35	160.6	401	9	5.5	1.35				

注：1. 带*机型不能配置直联电机；

2. f_B栏有“O”的机型，不能使用电机100%功率，运转时负载转矩请保持在表中“Ma”以下，为了保护主机，请自加安全装置；

3. 所有机型均可配置对应相同电机机座号的6P、8P电机；

4. 三级传动许用输出扭矩、用径向力值参照二级传动中的最大值。

选型参数表

n _a [r/min]	M _a [Nm]	i	F _{ra}		f _b	机型号	极数	n _a [r/min]	M _a [Nm]	i	F _{ra}		f _b	机型号	极数
			[kN]	Hz							[kN]	Hz			
11kW			频率	Hz	50		11kW			频率	Hz	50			
			极数	P	4	6				极数	P	4	6		
			转速 n	r/min	1460	970				转速 n	r/min	1460	970		
1.0	29400	1505	158.4	O	B95 X128	4P	22.6	4191	43	49.6	1.35	B6* X9*	6P		
1.1	29400	1357	158.4	O			27.7	3411	35	46.9	1.80				
1.2	29400	1225	158.4	O			33.4	2827	29	44.8	2.15				
1.5	29400	1003	158.4	O			42.2	2242	23	40.2	2.70				
1.7	29400	841	158.4	O			51.1	1852	19	37.2	2.70				
2.0	29400	731	158.4	O			57.1	1657	17	34.9	2.70				
2.2	29400	649	158.4	O			64.7	1462	15	34.2	2.70				
2.5	29400	595	158.4	O			74.6	1267	13	33.4	2.70				
3.0	26604	493	158.4	1.10			88.2	1072	11	32.6	2.70				
3.7	21100	391	158.4	1.35			20.6	4598	71	30.2	0.85				
4.6	17215	319	158.4	1.70	24.7	3821	59	28.1	0.90	B5 X8	4P				
5.8	13653	253	158.4	2.15	31.1	3044	47	27.0	1.35						
5.1	15596	289	91.7	1.35	34.0	2785	43	26.4	1.35						
5.8	13653	253	91.7	1.55	41.7	2266	35	26.4	1.70						
7.8	10091	187	91.7	2.10	50.3	1878	29	25.2	1.80						
11.5	6826	121	91.7	2.25	63.5	1489	23	22.2	2.25						
1.7	21500	841	91.7	O	76.8	1230	19	21.6	2.25			B4 X6 X7	4P		
2.0	21500	731	91.7	O	85.9	1101	17	20.9	2.25						
2.2	21500	649	91.7	O	97.3	971	15	19.2	2.25						
2.5	21500	595	91.7	O	112.3	842	13	16.8	2.25						
3.0	21500	493	91.7	O	132.7	712	11	15.4	2.25						
3.7	21100	391	91.7	1.00	41.7	2266	35	11.5	0.90						
4.6	17215	319	91.7	1.20	50.3	1878	29	11.5	0.90						
5.1	15596	289	91.7	1.35	63.5	1489	23	9.8	1.35						
5.8	13653	253	91.7	1.35	76.8	1230	19	9.4	1.35						
7.8	10091	187	91.7	1.35	85.9	1101	17	9.1	1.35						
11.5	6826	121	91.7	1.35	97.3	971	15	8.8	1.35	B3* X5*	4P				
14.1	5585	99	91.7	1.35	112.3	842	13	8.4	1.35						
3.7	12000	391	72.5	O	132.7	712	11	8.0	1.35						
4.6	12000	319	72.5	O	162.2	583	9	6.6	1.35						
5.1	12000	289	72.5	O	85.9	1101	17	6.7	0.85						
5.8	12000	253	72.5	O	97.3	971	15	6.5	0.85						
7.8	10091	187	72.5	1.15	112.3	842	13	6.2	0.90						
8.6	9201	165	72.5	1.30	132.7	712	11	5.9	0.90						
11.5	6826	121	72.5	1.35	162.2	583	9	5.5	0.90						
14.1	5585	99	72.5	1.35					频率			Hz	50		
4.6	8800	319	52.9	O					极数	P	4	6			
5.1	8800	289	52.9	O					转速 n	r/min	1460	970			
5.8	8800	253	52.9	O	B64 X96	4P	1.7	29400	841	158.4	O	B95 X128	4P		
7.8	8800	187	52.9	O			2.0	29400	731	158.4	O				
8.8	8800	165	52.9	O			2.2	29400	649	158.4	O				
10.2	7717	143	52.9	1.10			2.5	29400	595	158.4	O				
12.1	6530	121	52.9	1.30			3.0	29400	493	158.4	O				
14.7	5342	99	52.9	1.35			3.7	28773	391	158.4	1.00				
11.1	8480	87	72.5	1.15			4.6	23474	319	158.4	1.25				
13.7	6920	71	72.5	1.55			5.8	18618	253	158.4	1.55				
16.4	5751	59	66.5	1.90			2.5	21500	595	91.7	O				
20.6	4581	47	63.4	2.25			3.0	21500	493	91.7	O				
22.6	4191	43	62.2	2.60	3.7	21500	391	91.7	O	B85 X118	4P				
27.7	3411	35	58.9	2.60	4.6	21500	319	91.7	O						
11.1	8480	87	52.9	0.85	5.1	21267	289	91.7	1.00						
13.7	6920	71	52.9	0.85	5.8	18618	253	91.7	1.15						
16.4	5751	59	49.6	0.90	7.8	13761	187	91.7	1.55						
20.6	4581	47	49.6	1.35	11.5	9309	121	91.7	1.65						

- 注: 1. 带*机型不能配置直联电机;
 2. f_b栏有“O”的机型, 不能使用电机 100%功率, 运转时负载转矩请保持在表中“Ma”以下, 为了保护主机, 请自加安全装置;
 3. 所有机型均可配置对应相同电机机座号的 6P、8P 电机;
 4. 三级传动许用输出扭矩、许用径向力值参照二级传动中的最大值。

选型参数表

na	Ma	i	Fra	fb	机型号	极数	na	Ma	i	Fra	fb	机型号	极数
[r/min]	[Nm]		[kN]				[r/min]	[Nm]		[kN]			
15kW			频率	Hz	50		18.5kW			频率	Hz	50	
			极数	P	4	6				极数	P	4	6
			转速 n	r/min	1460	970				转速 n	r/min	1470	980
11.1	11563	87	72.5	0.80	B7* X10*	6P	11.1	14261	87	91.7	1.30	B8* X11*	6P
13.7	9437	71	72.5	1.15			13.7	11639	71	91.7	1.65		
16.4	7842	59	66.5	1.40			16.4	9672	59	84.1	2.00		
20.6	6247	47	63.4	1.65			22.6	7049	43	78.7	2.70		
22.6	5715	43	62.2	1.90			27.7	5737	35	74.5	3.25		
27.7	4652	35	58.9	1.90			13.7	11639	71	72.5	0.90		
33.4	3854	29	56.2	2.60			16.4	9672	59	66.5	1.15		
42.2	3057	23	47.8	3.20			20.6	7704	47	63.4	1.35		
57.1	2260	17	47.8	3.20			22.6	7049	43	62.2	1.50		
62.6	2060	15	44.4	3.20			27.7	5737	35	58.9	1.50		
84.3	1528	11	40.9	3.20			33.4	4754	29	56.2	2.10		
20.6	6247	47	49.6	0.95			42.2	3770	23	47.8	2.60		
22.6	5715	43	49.6	0.95	57.1	2787	17	47.8	2.60				
27.7	4652	35	46.9	1.35	62.6	2541	15	44.4	2.60				
33.4	3854	29	44.8	1.60	84.3	1885	11	40.9	2.60				
42.2	3057	23	40.2	1.95	22.6	7049	43	49.6	0.80				
51.1	2525	19	37.2	1.95	27.7	5737	35	46.9	1.05				
57.1	2260	17	34.9	1.95	33.4	4754	29	44.8	1.30				
64.7	1994	15	34.2	1.95	42.2	3770	23	40.2	1.60				
74.6	1728	13	33.4	1.95	51.1	3115	19	37.2	1.60				
88.2	1462	11	32.6	1.95	57.1	2787	17	34.9	1.60				
31.1	4150	47	27.0	0.95	64.7	2459	15	34.2	1.60				
34.0	3797	43	26.4	0.95	74.6	2131	13	33.4	1.60				
41.7	3091	35	26.4	1.25	88.2	1803	11	32.6	1.60				
50.3	2561	29	25.2	1.35	42.0	3786	35	26.4	1.00				
63.5	2031	23	22.2	1.65	50.7	3137	29	25.2	1.00				
76.8	1678	19	21.6	1.65	63.9	2488	23	22.2	1.35				
85.9	1501	17	20.9	1.65	77.4	2055	19	21.6	1.35				
97.3	1325	15	19.2	1.65	86.5	1839	17	20.9	1.35				
112.3	1148	13	16.8	1.65	98.0	1623	15	19.2	1.35				
132.7	971	11	15.4	1.65	113.1	1406	13	16.8	1.35				
63.5	2031	23	9.8	0.95	133.6	1190	11	15.4	1.35				
76.8	1678	19	9.4	0.95	22kW			频率	Hz	50			
85.9	1501	17	9.1	0.95				极数	P	4	6		
97.3	1325	15	8.8	0.95				转速 n	r/min	1470	980		
112.3	1148	13	8.4	0.95							B8* X11*	6P	
132.7	971	11	8.0	0.95	11.1	16960	87	91.7	1.10				
162.2	795	9	6.6	0.95	13.7	13841	71	91.7	1.40				
18.5kW			频率	Hz	50		16.4	11501	59	84.1			1.70
			极数	P	4	6	22.6	8382	43	78.7			2.25
			转速 n	r/min	1470	980	27.7	6823	35	74.5			2.75
1.7	29400	841	158.4	O	B95 X128	4P	33.4	5653	29	71.2	3.35	B7* X10*	6P
2.0	29400	731	158.4	O			42.2	4438	23	64.4	3.35		
2.3	29400	649	158.4	O			57.1	3280	17	60.5	3.35		
2.5	29400	595	158.4	O			84.3	2219	11	54.0	3.35		
3.0	29400	493	158.4	O			16.4	11501	59	66.5	0.95		
3.8	29400	391	158.4	O			20.6	9162	47	63.4	1.10		
4.6	28755	319	158.4	1.00			22.6	8382	43	62.2	1.30		
5.8	22805	253	158.4	1.25			27.7	6823	35	58.9	1.30		
3.8	21500	391	91.7	O	33.4	5653	29	56.2	1.75				
4.6	21500	319	91.7	O	42.2	4484	23	47.8	2.15				
5.1	21500	289	91.7	O	57.1	3314	17	47.8	2.15				
5.8	21500	253	91.7	O	62.6	3022	15	44.4	2.15				
7.9	16856	187	91.7	1.25	84.3	2242	11	40.9	2.15				
11.6	11403	121	91.7	1.35									

注：1. 带*机型不能配置直联电机；

2. fb栏有“O”的机型，不能使用电机100%功率，运转时负载转矩请保持在表中“Ma”以下，为了保护主机，请自加安全装置；

3. 所有机型均可配置对应相同电机机座号的6P、8P电机；

4. 三级传动许用输出扭矩、许用径向力值参照二级传动中的最大值。

选型参数表

n _a [r/min]	M _a [Nm]	i	F _{ra}		f _B	机型号	极数	n _a [r/min]	M _a [Nm]	i	F _{ra}		f _B	机型号	极数				
			[kN]	Hz							[kN]	Hz							
22kW			频率	Hz	50		37kW			频率	Hz	50							
			极数	P	4	6				极数	P	4	6						
			转速 n	r/min	1470	980				转速 n	r/min	1475	980						
27.7	6823	35	46.9	0.90	B6* X9*	6P	16.6	19146	59	84.1	1.00	B8* X11*	6P						
33.4	5653	29	44.8	1.05			22.8	13954	43	78.7	1.35								
42.2	4484	23	40.2	1.35			28.0	11358	35	74.5	1.60								
51.1	3704	19	37.2	1.35			33.8	9411	29	71.2	2.00								
57.1	3314	17	34.9	1.35			42.6	7464	23	64.4	2.00								
64.7	2924	15	34.2	1.35			57.6	5517	17	60.5	2.00								
74.6	2534	13	33.4	1.35			85.2	3732	11	54.0	2.00								
88.2	2144	11	32.6	1.35			33.8	9411	29	56.2	1.00								
30kW			频率	Hz	50					频率	Hz	50							
			极数	P	4	6				极数	P	4	6						
			转速 n	r/min	1470	980				转速 n	r/min	1475	980						
11.3	22891	87	158.4	1.30	B9* X12*	6P	45kW			频率	Hz	50							
13.8	18681	71	158.4	1.60						极数	P	4	6						
16.6	15524	59	158.4	1.85						转速 n	r/min	1475	980						
22.8	11314	43	150.0	2.45			13.8	28021	71	158.4	1.05	B9* X12*	6P						
28.0	9209	35	121.2	2.90			16.6	23285	59	158.4	1.25								
33.8	7630	29	121.2	3.35			22.8	16971	43	150.0	1.65								
42.6	6052	23	121.2	3.35			28.0	13813	35	121.2	1.95								
11.3	22891	87	91.7	0.80			33.8	11445	29	121.2	2.25			B8* X11*	6P				
13.8	18681	71	91.7	1.00	42.6	9077	23	121.2	2.25										
16.6	15524	59	84.1	1.25	22.8	16971	43	78.7	1.10										
22.8	11314	43	78.7	1.65	28.0	13813	35	74.5	1.35										
28.0	9209	35	74.5	2.00	33.8	11445	29	71.2	1.65										
33.8	7630	29	71.2	2.45	42.6	9077	23	64.4	1.65										
42.6	6052	23	64.4	2.45	57.6	6709	17	60.5	1.65										
57.6	4473	17	60.5	2.45	85.2	4539	11	54.0	1.65										
85.2	3026	11	54.0	2.45	33.8	11445	29	56.2	0.85	B7* X10*	6P								
22.8	11314	43	62.2	0.95	42.6	9077	23	47.8	1.00										
28.0	9209	35	58.9	0.95	57.6	6709	17	47.8	1.00										
33.8	7630	29	56.2	1.30	63.2	6117	15	44.4	1.00										
42.6	6052	23	47.8	1.60	85.2	4539	11	40.9	1.00										
57.6	4473	17	47.8	1.60	55kW			频率	Hz			50							
63.2	4078	15	44.4	1.60				极数	P			4	6						
85.2	3026	11	40.9	1.60				转速 n	r/min			1480	980						
42.6	6052	23	40.2	0.95	B6* X9*	6P	16.6	28460	59	158.4	1.00	B9* X12*	6P						
51.6	4999	19	37.2	0.95			22.8	20742	43	150.0	1.35								
57.6	4473	17	34.9	0.95			28.0	16883	35	121.2	1.60								
65.3	3947	15	34.2	0.95			33.8	13989	29	121.2	1.80								
75.4	3420	13	33.4	0.95			42.6	11095	23	121.2	1.80								
89.1	2894	11	32.6	0.95			28.0	16883	35	74.5	1.10								
37kW			频率	Hz			50							频率	Hz	50			
			极数	P			4	6						极数	P	4	6		
			转速 n	r/min	1475	980				转速 n	r/min	1480	980						
11.3	28232	87	158.4	1.05	B9* X12*	6P	75kW			频率	Hz	50							
13.8	23040	71	158.4	1.30						极数	P	4	6						
16.6	19146	59	158.4	1.50						转速 n	r/min	1480	980						
22.8	13954	43	150.0	2.00			22.8	27999	43	150.0	0.95	B9* X12*	6P						
28.0	11358	35	121.2	2.35			28.0	22790	35	121.2	1.15								
33.8	9411	29	121.2	2.70			33.8	18883	29	121.2	1.35								
42.6	7464	23	121.2	2.70			42.6	14976	23	121.2	1.35								

注：1. 带*机型不能配置直联电机；

2. f_B栏有“O”的机型，不能使用电机100%功率，运转时负载转矩请保持在表中“M_a”以下，为了保护主机，请自加安全装置；

3. 所有机型均可配置对应相同电机机座号的6P、8P电机；

4. 三级传动许用输出扭矩、许用径向力值参照二级传动中的最大值。

3 外形及安装尺寸

3.1 BW、BWD、XW、XWD型 (单级) 外形安装尺寸

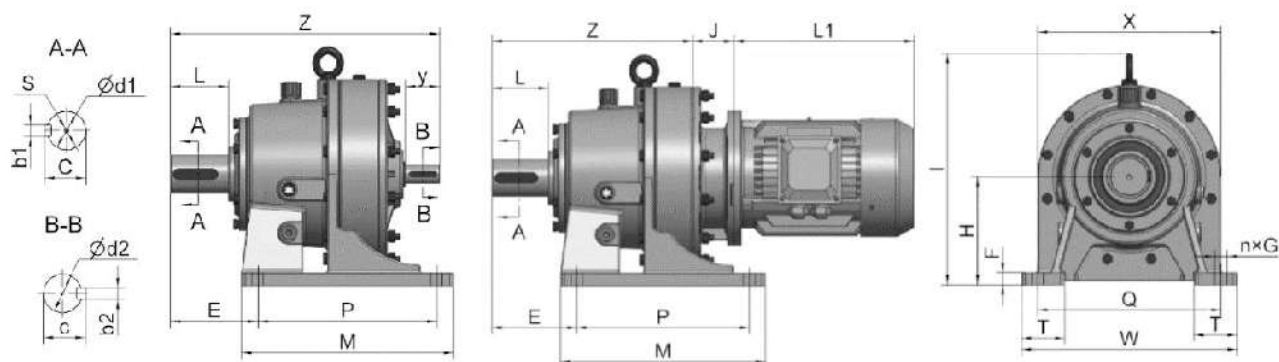

机型号	中心 高 H	轴端尺寸								安装尺寸								外形尺寸					
		输出轴				输入轴				E	F	P	Q	S	T	N	ΦG	M	W	Z			
		d1 (h6)	b1	C	L	d2 (h6)	b2	c	y											BW	BWD	I	X
BW.BWD09-9																							
B09	80	22	6	24.5	30	15	5	17	22	46.5	12	76	120	M5	30	4	11	100	144	192	142	155	140
B0	100	30	8	33	35	15	5	17	22	94	15	90	150	M8	35	4	11	120	185	214	165	190	168
B1	120	35	10	38	56	18	6	20.5	35	125	14	110	240	M10	55	4	13	160	280	263	194	250	200
B2	140	45	14	48.5	71	22	6	24.5	40	144	19	150	280	M10	60	4	13	200	320	320	246	296	240
B3	160	55	16	59	80	30	8	33	55	156	23	200	340	M12	75	4	17	250	390	390	294	355	300
B4	200	70	20	74.5	104	35	10	38	62	157	23	320	340	M12	80	4	22	380	400	481	370	430	340
B5	240	90	25	95	122	45	14	48.5	70	160	33	380	420	M16	80	4	22	440	470	564	438	513	400
B6	280	100	28	106	139	50	14	53.5	80	199	35	440	500	M20	90	4	26	520	560	670	528	605	500
B7	325	110	28	116	150	55	16	59	90	230	45	250×2	630	M24	105	6	30	600	690	775	578	706	575
B8	420	130	32	137	202	70	20	74.5	120	325	50	330×2	800	M30	140	6	32	810	880	1063	814	880	700
B9	540	180	45	190	327	90	25	95	150	481	58	420×2	1050	M42	200	6	45	1040	1160	1458	1151	1160	950
XW.XWD1-12																							
X1	100	25	8	28	35	15	5	17	22	61	12	90	150	M5	30	4	12	120	180	199	147	175	140
X2	100	25	8	28	33	15	5	17	22	101	15	90	180	M8	45	4	12	120	210	216	164	190	168
X3	140	35	10	38	56	18	6	20.5	35	152	18	100	250	M10	60	4	16	150	290	263	194	270	200
X4	150	45	14	48.5	73	22	6	24.5	40	168	19	145	290	M10	65	4	16	195	330	324	246	316	240
X5	160	55	16	59	91	30	8	33	55	204	23	150	370	M12	70	4	16	260	410	401	305	356	300
X6	200	65	18	69	89	35	10	38	62	125	27	275	380	M12	75	4	22	335	430	466	359	425	340
X7	220	80	22	85	107	40	12	43	65	143	27	320	420	M12	90	4	22	380	470	486	377	484	340
X8	250	90	25	95	122	45	14	48.5	70	157	35	380	480	M16	100	4	22	440	530	564	438	514	400
X9	290	100	28	106	141	50	14	53.5	80	186	40	480	560	M20	120	4	26	560	620	691	551	614	500
X10	325	110	28	116	150	55	16	59	90	230	45	250×2	630	M24	105	6	30	600	690	775	578	706	575
X11	420	130	32	137	202	70	20	74.5	120	325	50	330×2	800	M30	140	6	32	810	880	1063	814	880	700
X12	540	180	45	190	327	90	25	95	150	481	58	420×2	1050	M42	200	6	45	1040	1160	1458	1151	1160	950

3.2 BL、BLD、XLW、XLD型 (单级) 外形安装尺寸

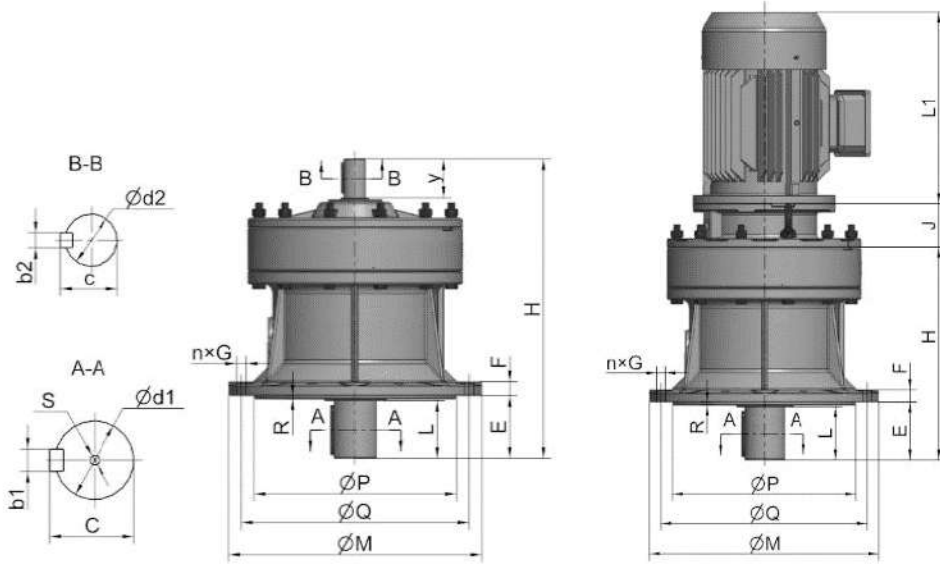

机型号	轴端尺寸								安装尺寸								外形尺寸		
	输出轴				输入轴				E	F	ΦG	N	P (h9)	Q	R	S	H		
	d1 (h6)	b1	C	L	d2 (h6)	b2	c	y									BL	BLD	M
BLBLD09-9																			
B09	22	6	24.5	30	15	5	17	22	35	10	11	4	110	134	3	M5	192	142	159
B0	30	8	33	35	15	5	17	22	39	14	11	4	140	160	3	M8	214	165	188
B1	35	10	38	47	18	6	20.5	35	61	15	11	6	170	200	4	M10	263	194	230
B2	45	14	48.5	61	22	6	24.5	40	70	16	11	6	200	230	4	M10	320	246	260
B3	55	16	59	74	30	8	33	55	79	20	13	6	270	310	4	M12	390	294	340
B4	70	20	74.5	92	35	10	38	62	100	22	15	8	320	360	5	M12	479	370	400
B5	90	25	95	110	45	14	48.5	70	118	30	18	12	400	450	5	M16	564	438	490
B6	100	28	106	130	50	14	53.5	80	138	35	22	12	460	520	8	M20	668	528	580
B7	110	28	116	142	55	16	59	90	182	40	22	12	520	590	10	M24	775	578	650
B8	130	32	137	202	70	20	74.5	120	211	50	38	12	680	800	10	M30	1061	814	880
B9	180	45	190	320	90	25	95	150	370	60	39	8	900	1020	10	M42	1459	1151	1160
XW.XWD1-12																			
X1	25	8	28	36	15	5	17	22	41	10	12	4	110	134	3	M5	201	147	159
X2	25	8	28	33	15	5	17	22	39	14	12	6	130	160	3	M8	216	164	180
X3	35	10	38	47	18	6	20.5	35	51	15	12	6	170	200	4	M10	263	194	230
X4	45	14	48.5	63	22	6	24.5	40	79	15	12	6	200	230	4	M10	324	250	260
X5	55	16	59	85	30	8	33	55	90	20	13	6	270	310	4	M12	401	305	340
X6	65	18	69	80	35	10	38	62	90	22	16	8	316	360	5	M12	466	359	400
X7	80	22	85	97	40	12	43	65	114	22	18	8	345	390	5	M12	486	377	430
X8	90	25	95	110	45	14	48.5	70	118	30	18	12	400	450	5	M16	564	438	490
X9	100	28	106	134	50	14	53.5	80	170	35	22	12	455	520	8	M20	694	551	580
X10	110	28	116	142	55	16	59	90	182	40	22	12	520	590	10	M24	775	578	650
X11	130	32	137	202	70	20	74.5	120	211	50	38	12	680	800	10	M30	1061	814	880
X12	180	45	190	320	90	25	95	150	370	60	39	8	900	1020	10	M42	1459	1151	1160

3.3 BWE、BWED、XWE、XWED型 (双级) 外形安装尺寸

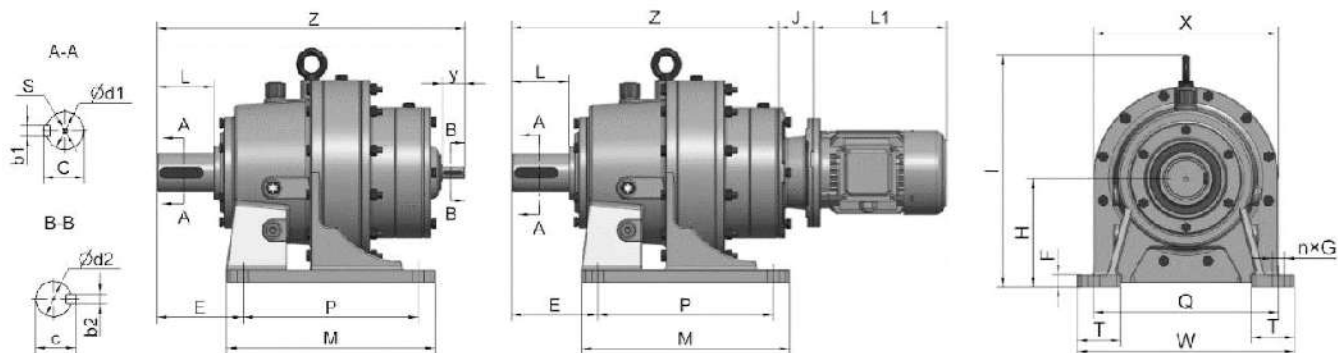

机型号	中心 高 H	轴端尺寸								安装尺寸								外形尺寸					
		输出轴				输入轴				E	F	P	Q	S	T	N	ΦG	M	W	Z		I	X
		d1 (h6)	b1	C	L	d2 (h6)	b2	c	y											BWE	BWED		
BWE.BWED10-95																							
B10	120	35	10	38	56	15	5	17	22	125	14	110	240	M10	55	4	13	160	280	317	267	250	200
B20	140	45	14	48.5	71	15	5	17	22	144	19	150	280	M10	60	4	13	200	320	369	315	306	240
B31	160	55	16	59	80	18	6	20.5	35	156	23	200	340	M12	75	4	17	250	390	443	376	356	300
B41	200	70	20	74.5	104	18	6	20.5	35	157	23	320	340	M12	80	4	22	380	400	523	454	425	340
B42	200	70	20	74.5	104	22	6	24.5	40	157	23	320	340	M12	80	4	22	380	400	554	479	425	340
B52	240	90	25	95	122	22	6	24.5	40	160	33	380	420	M16	80	4	22	440	470	623	548	504	400
B53	240	90	25	95	122	30	8	33	55	160	33	380	420	M16	80	4	22	440	470	661	561	504	400
B63	280	100	28	106	139	30	8	33	55	199	35	440	500	M20	90	4	26	520	560	746	645	605	500
B64	280	100	28	106	139	35	10	38	62	199	35	440	500	M20	90	4	26	520	560	783	671	605	500
B74	325	110	28	116	150	35	10	38	62	230	45	250×2	630	M24	105	6	30	600	690	836	725	706	575
B84	420	130	32	137	202	35	10	38	62	325	50	330×2	800	M30	140	6	32	810	880	1074	962	880	700
B85	420	130	32	137	202	45	14	48.5	70	325	50	330×2	800	M30	140	6	32	810	880	1098	970	880	700
B95	540	180	45	190	327	45	14	48.5	70	481	58	420×2	1050	M42	200	6	45	1040	1160	1440	1320	1160	950
XWE.XWED32-128																							
X32	140	35	10	38	56	15	5	17	22	152	18	100	250	M10	60	4	16	150	290	317	264	270	200
X42	150	45	14	48.5	73	15	5	17	22	168	19	145	290	M10	65	4	16	195	330	370	315	316	240
X53	160	55	16	59	91	18	6	20.5	35	204	23	150	370	M12	70	4	16	260	410	457	387	356	300
X63	200	65	18	69	89	18	6	20.5	35	125	27	275	380	M12	75	4	22	335	430	510	441	425	340
X64	200	65	18	69	89	22	6	24.5	40	125	27	275	380	M12	75	4	22	335	430	541	466	425	340
X74	220	80	22	85	107	22	6	24.5	40	143	27	320	420	M12	90	4	22	380	470	561	486	484	340
X84	250	90	25	95	122	22	6	24.5	40	157	35	380	480	M16	100	4	22	440	530	626	548	514	400
X85	250	90	25	95	122	30	8	33	55	157	35	380	480	M16	100	4	22	440	530	662	586	514	400
X95	290	100	28	106	141	30	8	33	55	186	40	480	560	M20	120	4	26	560	620	768	667	614	500
X96	290	100	28	106	141	35	10	38	62	186	40	480	560	M20	120	4	26	560	620	805	695	614	500
X106	325	110	28	116	150	35	10	38	62	230	45	250×2	630	M24	105	6	30	600	690	836	725	706	575
X117	420	130	32	137	202	40	12	43	65	325	50	330×2	800	M30	140	6	32	810	880	1077	962	880	700
X118	420	130	32	137	202	45	14	48.5	70	325	50	330×2	800	M30	140	6	32	810	880	1098	970	880	700
X128	540	180	45	190	327	45	14	48.5	70	481	58	420×2	1050	M42	200	6	45	1040	1160	1440	1320	1160	950

3.4 BLE、BLED、XLE、XLED型 (双级) 外形安装尺寸

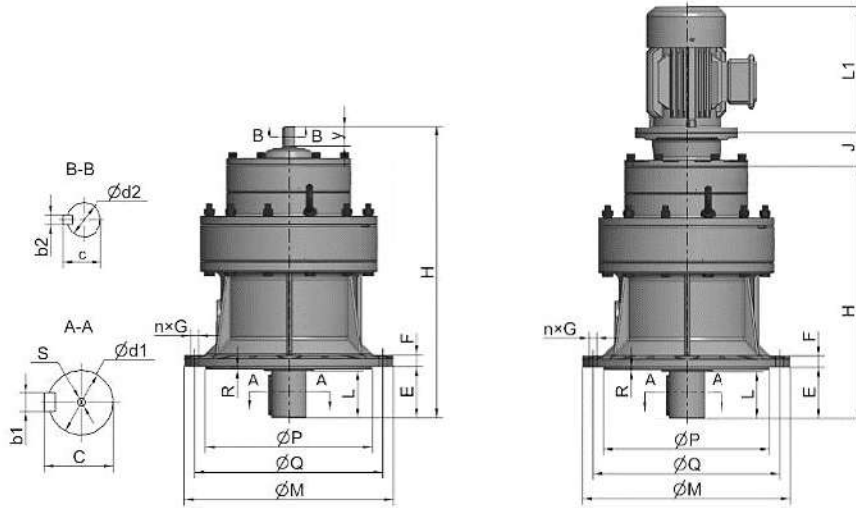

机型号	轴端尺寸								安装尺寸								外形尺寸		
	输出轴				输入轴				E	F	ΦG	N	P (h9)	Q	R	S	H		
	d1 (h6)	b1	C	L	d2 (h6)	b2	c	y									BLE	BLED	M
BLE.BLED10-95																			
B10	35	10	38	47	15	5	17	22	61	15	11	6	170	200	4	M10	317	267	230
B20	45	14	48.5	61	15	5	17	22	70	16	11	6	200	230	4	M10	368	318	260
B31	55	16	59	74	18	6	20.5	35	79	20	13	6	270	310	4	M12	446	376	340
B41	70	20	74.5	92	18	6	20.5	35	100	22	15	8	320	360	5	M12	521	454	400
B42	70	20	74.5	92	22	6	24.5	40	100	22	15	8	320	360	5	M12	554	479	400
B52	90	25	95	110	22	6	24.5	40	118	30	18	12	400	450	5	M16	627	548	490
B53	90	25	95	110	30	8	33	55	118	30	18	12	400	450	5	M16	663	561	490
B63	100	28	106	130	30	8	33	55	138	35	22	12	460	520	8	M20	745	645	580
B64	100	28	106	130	35	10	38	62	138	35	22	12	460	520	8	M20	780	671	580
B74	110	28	116	142	35	10	38	62	182	40	22	12	520	590	10	M24	836	725	650
B84	130	32	137	202	35	10	38	62	211	50	38	12	680	800	10	M30	1074	962	880
B85	130	32	137	202	45	14	48.5	70	211	50	38	12	680	800	10	M30	1098	970	880
B95	180	45	190	320	45	14	48.5	70	370	60	39	8	900	1020	10	M42	1440	1320	1160
XLE.XLED32-128																			
X32	35	10	38	47	15	5	17	22	51	15	12	6	170	200	4	M10	317	264	230
X42	45	14	48.5	63	15	5	17	22	79	15	12	6	200	230	4	M10	370	320	260
X53	55	16	59	85	18	6	20.5	35	90	20	13	6	270	310	4	M12	457	389	340
X63	65	18	69	80	18	6	20.5	35	90	22	16	8	316	360	5	M12	510	441	400
X64	65	18	69	80	22	6	24.5	40	90	22	16	8	316	360	5	M12	546	466	400
X74	80	22	85	97	22	6	24.5	40	114	22	18	8	345	390	5	M12	561	486	430
X84	90	25	95	110	22	6	24.5	40	118	30	18	12	400	450	5	M16	627	548	490
X85	90	25	95	110	30	8	33	55	118	30	18	12	400	450	5	M16	663	588	490
X95	100	28	106	134	30	8	33	55	170	35	22	12	455	520	8	M20	770	667	580
X96	100	28	106	134	35	10	38	62	170	35	22	12	455	520	8	M20	807	694	580
X106	110	28	116	142	35	10	38	62	182	40	22	12	520	590	10	M24	836	725	650
X117	130	32	137	202	40	12	43	65	211	50	38	12	680	800	10	M30	1077	983	880
X118	130	32	137	202	45	14	48.5	70	211	50	38	12	680	800	10	M30	1098	970	880
X128	180	45	190	320	45	14	48.5	70	370	60	39	8	900	1020	10	M42	1440	1320	1160

3.5 电机接盘型联接法兰尺寸图表

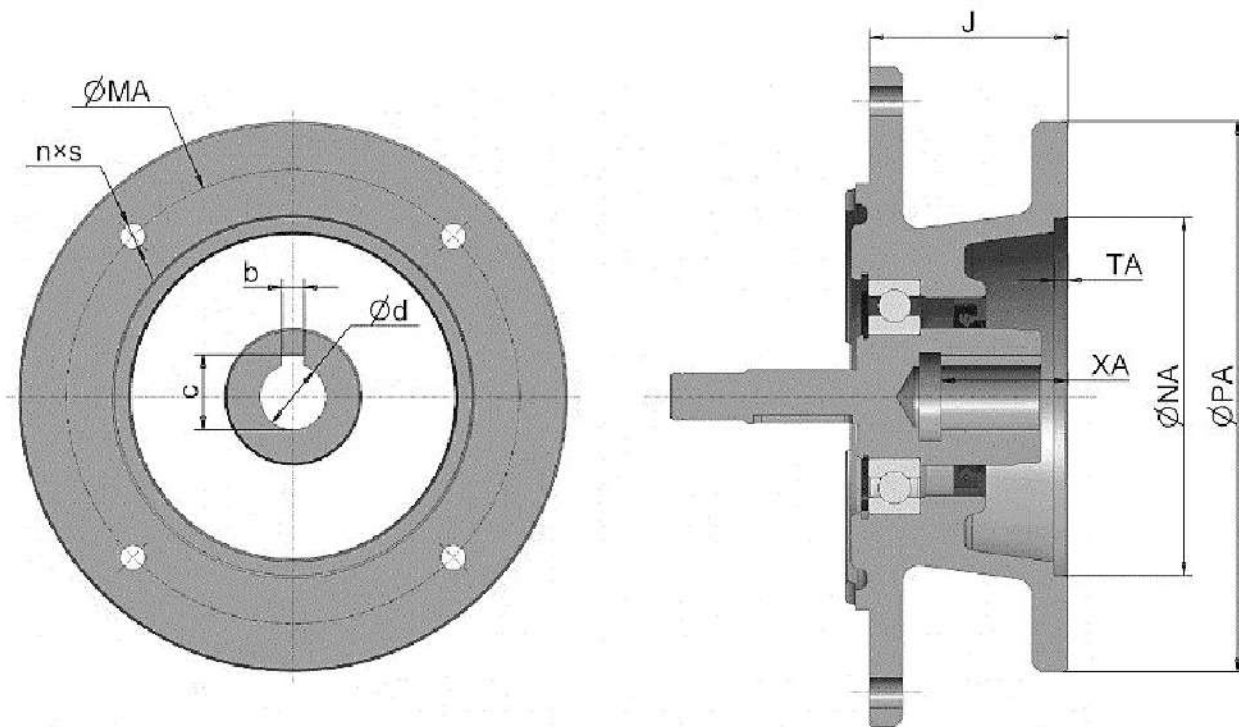

机型号	配置电机			尺寸									
	kW	机座号	极数	NA	MA	PA	J	TA	n×S	XA	d	b	c
B09/X1	0.18	63	4P	95	115	140	54	4	4×M8	23	11	4	12.8
	0.25、0.37	71		110	130	160	71	4	4×M8	30	14	5	16.3
	0.55	80		130	165	200	71	4	4×M10	40	19	6	21.8
B0/X2 B10/X32 B20/X42	0.18	63		95	115	140	55	4	4×M8	23	11	4	12.8
	0.25、0.37	71		110	130	160	72	4	4×M8	30	14	5	16.3
	0.55、0.75	80		130	165	200	82	4	4×M10	40	19	6	21.8
	1.1	90S		130	165	200	82	4	4×M10	50	24	8	27.3
B1/X3 B31/X53 B41/63	0.25、0.37	71		110	130	160	84	4	4×M8	30	14	5	16.3
	0.55、0.75	80		130	165	200	79	4	4×M10	40	19	6	21.8
	1.1、1.5	90		130	165	200	79	4	4×M10	50	24	8	27.3
	2.2	100L		180	215	250	88	4.5	4×M12	60	28	8	31.3
B2/X4 B42/X64 B52/X84	0.55、0.75	80		130	165	200	72	5	4×M10	40	19	6	21.8
	1.1、1.5	90	130	165	200	72	5	4×M10	50	24	8	27.3	
	2.2、3	100L	180	215	250	72	5	4×M12	60	28	8	31.3	
	4	112M	180	215	250	72	5	4×M12	60	28	8	31.3	

机型号	配置电机			尺寸									
	kW	机座号	极数	NA	MA	PA	J	TA	n×S	XA	d	b	c
B3/X5 B53/X85 B63/X95	0.55、0.75	80	4P	130	165	200	73	5	4×M10	40	19	6	21.8
	1.1、1.5	90		130	165	200	73	5	4×M10	50	24	8	27.3
	2.2、3	100L		180	215	250	73	5	4×M12	60	28	8	31.3
	4	112M		180	215	250	73	5	4×M12	60	28	8	31.3
	5.5、7.5	132		230	265	300	112	5	4×M12	80	38	10	41.3
	11	160M		250	300	350	151	5	4×M16	110	42	12	45.3
B4/X6/X7 B74/X106 B84/X117	2.2、3	100L		180	215	250	76	5	4×M12	60	28	8	31.3
	4	112M		180	215	250	76	5	4×M12	60	28	8	31.3
	5.5、7.5	132		230	265	300	97	5	4×M12	80	38	10	41.3
	11	160M		250	300	350	151	5	4×M16	110	42	12	45.3
B5/X8 B85/X118 B95/X128	2.2、3	100L		180	215	250	142	6	4×M12	60	28	8	31.3
	4	112M		180	215	250	142	6	4×M12	60	28	8	31.3
	5.5、7.5	132		230	265	300	95	5	4×M12	80	38	10	41.3
	11、15	160		250	300	350	127	6	4×M16	110	42	12	45.3
	18.5	180M		250	300	350	127	6	4×M16	110	48	14	51.8
B6/X9	5.5	132M		230	265	300	144	6	4×M12	80	38	10	41.3
	7.5、11	160		250	300	350	121	6	4×M16	110	42	12	45.3
	15	180L		250	300	350	121	6	4×M16	110	48	14	51.8
	18.5、22	200L	300	350	400	124	6	4×M16	110	55	16	59.3	
B7/X10	7.5、11	160	250	300	350	129	6	4×M16	110	42	12	45.3	
	15	180L	250	300	350	129	6	4×M16	110	48	14	51.8	
	18.5、22	200L	300	350	400	129	6	4×M16	110	55	16	59.3	
	30	225M	350	400	450	161	7	8×M16	140	60	18	64.4	
	37	250M	450	500	550	161	7	8×M16	140	65	18	69.4	
B8/X11	18.5、22	200L	300	350	400	204	7	4×M16	110	55	16	59.3	
	30	225M	350	400	450	165	7	8×M16	140	60	18	64.4	
	37	250M	450	500	550	229	7	8×M16	140	65	18	69.4	
	45、55	280	450	500	550	229	7	8×M16	140	75	20	79.9	
B9/X12	30	225M	350	400	450	236	7	8×M16	140	60	18	64.4	
	37	250M	450	500	550	236	7	8×M16	140	65	18	69.4	
	45、55	280	450	500	550	236	7	8×M16	140	75	20	79.9	
	75	315S	550	600	660	266	7	8×M20	170	80	22	85.4	

3.6 三相异步电机-B5外形及安装尺寸

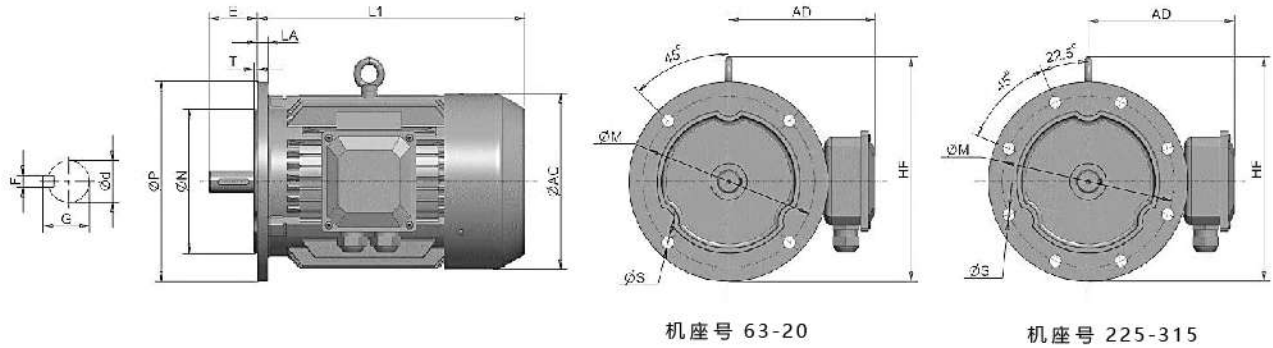

机座号	额定功率 4P (kW)	额定功率 6P (kW)	d		E		F		G		M	N	P	S	T	AC	AD	LA	HF	L1	
			4-10P	4-10P	4-10P	4-10P	4-10P	4-10P	4-10P												
63M	0.18		11	23	4	12.5	115	95	140					10	3	130	70	10	130	207	
71M1	0.25	0.18	14	30	5	16	130	110	160											225	
71M2	0.37	0.25																		145	80
80M1	0.55	0.37	19	40	6	21.5	165	130	200					12	3.5	175	145	12	185	255	
80M2	0.75	0.55																			12
90S	1.1	0.75	24	50		27														270	
90L	1.5	1.1																		12	195
100L1	2.2	1.5	28	60	8				250												325
100L2	3																				31
112M	4	2.2												15	4						340
132S	5.5	3																			14
132M1	7.5	4	38	80	10	41	265	230	300												430
132M2		5.5																			14
160M	11	7.5	42		12	45			350	250	350										505
160L	15	11																			16
180M	18.5		48	110	14	51.5															590
180L	22	15																			18
200L1	30	18.5	55		16	59	350	300	400												660
200L2		22																			18
225S	37		60	140	18	64	400	350	450												675
225M	45	30																			64
250M	55	37	65		18	69															770
280S	75	45																			510
280M	90	55	75	140	20	79.5	500	450	550												845
315S	110	75																			580

3.7 IEC电动机形位公差要求

用户自配或自备电机，须达到以下形位公差要求

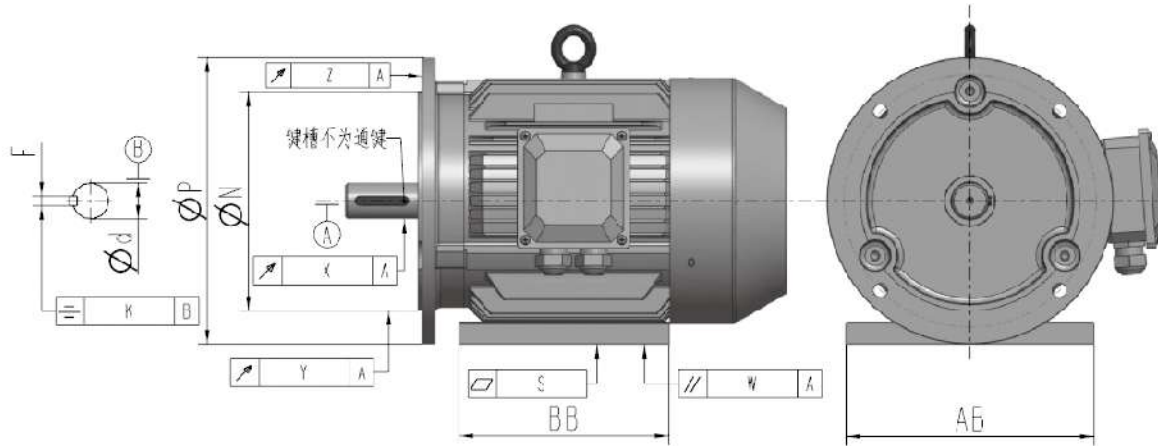

1. 电动机安装面各项跳动 (B5、B35)

机座号	轴伸跳动 (X)		止口跳动 (Y)		端面跳动 (Z)	
	轴伸直径 (d)	9级 (轴伸一半处)	凸缘止口直径 (N)	9级	外圆直径 (P)	9级
63 ~ 315	10~18	0.04	60~95	0.08	60~95	0.08
	18~30	0.04	>95~230	0.1	>95~230	0.1
	>30~50	0.05	>230~450	0.125	>230~450	0.125
	>50~80	0.06	>450~680	0.16	>450~680	0.16

2. 电动机轴伸上键槽对称度公差 (B5、B35)

键槽宽度 (F)	对称度公差 (K)
4	0.018
5	
6	
8	0.022
10	
12	
14	0.030
16	
18	
20	
22	0.037

3. 电动机轴线对底脚支承面的平行度公差 (B35)

机座号	平行度公差 (W)
63 ~ 250	0.40
> 250 ~ 315	0.75

4. 电动机底脚支承面的平面度公差 (B35)

AB或BB中最大尺寸	平面度公差 (S)
> 100 ~ 160	0.12
> 160 ~ 250	0.15
> 250 ~ 400	0.20
> 400 ~ 630	0.25
> 630 ~ 1000	0.30

3.8 减速机及电机重量

1) 一级电机直联型减速机重量 (单位: kg)

规格	BW09	BW0	BW1	BW2	BW3	BW4	BW5	XW1	XW2	XW3
重量	8	9	18	31	54	93	145	9	9	18
规格	XW4	XW5	XW6	XW7	XW8	BL09	BL0	BL1	BL2	BL3
重量	32	55	93	103	160	8	8	18	29	54
规格	BL4	BL5	XL1	XL2	XL3	XL4	XL5	XL6	XL7	XL8
重量	90	146	8	8	18	29	54	93	98	146

2) 一级电机接盘型/双轴型减速机重量 (单位: kg)

规格	BW09	BW0	BW1	BW2	BW3	BW4	BW5	BW6	BW7	BW8	BW9	XW1
重量	12	15	25	42	71	119	181	347	500	1047	2347	13
规格	XW2	XW3	XW4	XW5	XW6	XW7	XW8	XW9	XW10	XW11	XW12	BL09
重量	15	25	42	72	119	129	197	348	500	1047	2347	12
规格	BL0	BL1	BL2	BL3	BL4	BL5	BL6	BL7	BL8	BL9	XL1	XL2
重量	14	25	40	71	116	183	344	512	1010	2416	12	14
规格	XL3	XL4	XL5	XL6	XL7	XL8	XL9	XL10	XL11	XL12		
重量	25	40	71	119	123	183	353	512	1010	2416		

3) 二级电机直联型减速机重量 (单位: kg)

规格	BWE10	BWE20	BWE31	BWD41	BWE42	BWE52	BWE53	BWE63	BWE64	BWE74	BWE84
重量	28	42	74	117	127	186	196	357	378	534	1024
规格	BWE85	BWE95	XWE32	XWE42	XWE53	XWE63	XWE64	XWE74	XWE84	XWE85	XWE95
重量	1054	2243	28	43	75	117	127	137	201	211	358
规格	XWE96	XWE106	XWE117	XWE118	XWE128	BLE10	BLE20	BLE31	BLE41	BLE42	BLE52
重量	378	534	1024	1054	2243	28	42	73	114	124	188
规格	BLE53	BLE63	BLE64	BLE74	BLE84	BLE85	BLE95	XLE32	XLE42	XLE53	XLE63
重量	198	354	373	544	987	1017	2174	28	42	73	117
规格	XLE64	XLE74	XLE84	XLE85	XLE95	XLE96	XLE106	XLE117	XLE118	XLE128	
重量	127	131	188	198	363	383	544	987	1017	2174	

4) 二级电机接盘型/双轴型减速机重量 (单位: kg)

规格	BWE10	BWE20	BWE31	BWD41	BWE42	BWE52	BWE53	BWE63	BWE64	BWE74	BWE84
重量	34	49	81	124	138	197	213	374	421	557	1050
规格	BWE85	BWE95	XWE32	XWE42	XWE53	XWE63	XWE64	XWE74	XWE84	XWE85	XWE95
重量	1090	2210	34	50	82	124	138	148	212	228	380
规格	XWE96	XWE106	XWE117	XWE118	XWE128	BLE10	BLE20	BLE31	BLE41	BLE42	BLE52
重量	422	557	1050	1090	2210	34	47	81	121	135	199
规格	BLE53	BLE63	BLE64	BLE74	BLE84	BLE85	BLE95	XLE32	XLE42	XLE53	XLE63
重量	215	371	417	569	1013	1053	2279	34	48	81	124
规格	XLE64	XLE74	XLE84	XLE85	XLE95	XLE96	XLE106	XLE117	XLE118	XLE128	
重量	138	142	199	215	375	427	569	1013	1053	2279	

注: 上述减速机重量为平均值, 不包含电机重量, 仅供参考。

5) 三相异步电动机-B5 重量 (单位: kg)

电机型号	63M1-4	71M1-4	71M2-4	80M1-4	80M2-4	90S-4	90L-4	100L1-4	100L2-4	112M-4	132S-4
额定功率 (kW)	0.18	0.25	0.37	0.55	0.75	1.1	1.5	2.2	3	4	5.5
重量(kg)	8	10	10.5	14	14.7	21	27.5	31	35	41	65
电机型号	132M-4	160M-4	160L-4	180M-4	180L-4	200L-4	225S-4	225M-4	250M-4	280S-4	
额定功率 (kW)	7.5	11	15	18.5	22	30	37	45	55	75	
重量(kg)	71.5	110	132	164	190	245	285	325	400	553	
电机型号	180L-6	200L1-6	200L2-6	225M-6	250M-6	280S-6	280M-6	315S-6	315M-6	315L1-6	
额定功率 (kW)	15	18.5	22	30	37	45	55	75	90	110	
重量(kg)	180	222	235	290	375	492	550	930	1030	1150	

注: 不同厂家电机重量略有不同, 上述电机重量仅供参考。

4 使用及润滑须知

4.1 使用须知

1. 减速机适用于24小时连续工作制，并允许正反向运转。
2. 一级传动减速机的输出轴转向与输入轴转向相反，二级传动减速机的输出轴转向与输入轴转向相同。
3. 减速机无自锁功能。如用于升降装置等危险场合时，应选用制动电机或在输入端加配制动装置。
4. 减速机的输出轴不能承受轴向力。
5. 在可能出现过载现象的使用场合，应安装过载保护装置。
6. 地脚式减速机要安装在没有振动、十分坚固的水平基础上。在必须倾斜安装的使用场合，减速机轴心线的倾斜度不得大于 $\pm 15^\circ$ 。
7. 当减速机在工作条件恶劣、启停频繁和高温或低温场合工作时，请与我公司技术部联系。
8. 减速机的输入轴和输出轴的轴伸形式为圆柱形，采用普通平键联接。普通平键尺寸按GB1096《普通型 平键》的规定。
9. 减速机与相配套机械用联轴器联接时，两者轴心线同轴度不得超过联轴器所允许的范围。
10. 当减速器与齿轮、链轮相联接时，必须保证两者轴心线的平行度。
11. 当使用链轮来进行传动时，不要把齿链放的过松，否则在启动时会产生冲击力，壳体材料建议改为球墨铸铁，以加强壳体强度。
12. 在把联轴器、齿轮、链轮等联接件联接减速机的输出轴时，不得采用直接锤击的方法，应利用轴伸端螺孔旋入螺栓，通过压板压入。
13. 安装后的减速机，正式使用前必须进行试运转。在空载运转正常的情况下，再逐渐加载运转。

4.2 润滑须知

1. 润滑方式

一级传动润滑方式

机型号 安装形式	B09	B0	B1	B2	B3	B4	B5	B6	B7	B8	B9
脚板式 M1 安装	脂润滑			油浴润滑		循环润滑					
法兰式 M4 安装	脂润滑			油浴润滑		循环润滑					

二级传动润滑方式

机型号 安装形式	B10	B20	B31	B41	B42	B52	B53	B63	B74	B84	B85	B95
脚板式 M1 安装	脂润滑			油浴润滑								
法兰式 M4 安装	脂润滑			循环润滑								

注: a. X系列减速机润滑方式参照对应B系列机型;

b. 其他安装型式时请与我公司技术部联系。

2. 凡上表中所列脂润滑机型, 出厂前均已注好, 可直接使用。以后1-2个月补充一次。推荐使用2# 锂基脂或00# 减速机脂。适合在-5℃~55℃环境温度下使用。其他特殊环境请与我公司技术部联系。

3. 采用油润滑机型, 出厂前油已放净, 在使用前请按油标要求加足油。推荐用润滑油见下表。

	国产 (中负荷极压齿轮油)	Esso 牌	Mobil 美孚牌	Shell 壳牌
-10℃~5℃	L-CKC68	Spartan EP 68	美孚齿轮油 626 (IOS VG68)	Omala 可耐压 68
0℃~35℃	L-CKC100 L-CKC150	Spartan EP 100 EP 150	美孚齿轮油 627 629 (IOS VG100,150)	Omala 可耐压 100 150
30℃~50℃	L-CKC220 L-CKC320	Spartan EP 220 EP 320	美孚齿轮油 630 632 633 634 (IOS VG200,320)	Omala 可耐压 220 320

4. 加注润滑油时, 油位高度不应超过油标上限, 也不应低于油标下限。在运转过程中, 应经常观察油位高度, 及时补充相同牌号的润滑油。

5. 其他使用维护要求, 请详见产品使用说明书, 编号NO.002M。

5 化工反应罐机架

5.1 JBT型 (79标) 搪玻璃反应罐机架

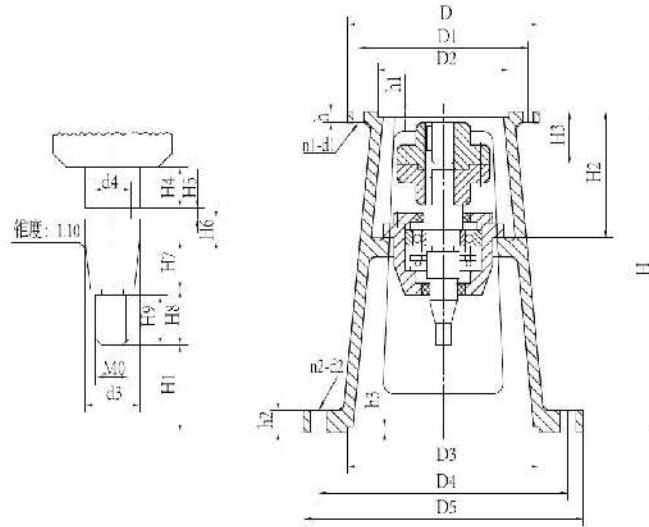

JBT 型 (79 标) 机架主要参数及尺寸

机架型号	输入端接口						输出端接口						H	H1	H2	H3
	D	D1	D2	h	h1	n1-d1	D3	D4	D5	h2	h3	n2-d2				
JBT1-B1(X3)	230	200	170	20	6	6-12	220	270	305	22	7	4-24	514	157	185	75
JBT2-B1(X3)	230	200	170	20	6	6-12	250	300	335	22	7	4-24	517	150	190	80
JBT2-B2(X4)	260	230	200	20	7	6-13	250	300	335	25	7	4-24	530	134	210	94
JBT3-B2(X4)	260	230	200	20	7	6-13	295	350	392	26	7	4-26	560	164	210	94
JBT3-B3(X5)	340	310	270	20	7	6-13	295	350	392	26	7	4-26	560	164	210	100
JBT4-B3(X5)	340	310	270	20	7	6-13	345	400	442	26	7	4-26	635	203	210	100
JBT5-B3(X5)	340	310	270	22	7	6-13	390	450	498	26	7	4-30	640	193	210	100
JBT5-B4(X6)	400	360	320(316)	22	7	8-16	390	450	498	26	7	4-30	680	193	250	120
JBT6-B4(X6)	400	360	320(316)	22	7	8-16	435	500	548	30	7	8-30	736	215	250	120
JBT6-X7	430	390	345	22	7	8-18	435	500	548	30	7	8-30	736	215	250	120
JBT6-B5(X8)	490	450	400	22	7	12-18	435	500	548	30	7	8-30	736	215	270	145
JBT7-B5(X8)	490	450	460(455)	26	10	12-18	440	550	600	30	10	12-22	805	180	296	145
JBT8-B6(X9)	580	520	460(455)	30	10	12-22	500	550	600	32	10	12-22	820	150	362	177
JBT9-B7(X10)	650	590	520	30	12	12-22	560	650	700	35	10	12-27	1100	326	455	204

机架型号	H4	H5	H6	H7	H8	H9	d3	d4	M0	反应罐容积 (升)
JBT1-B1(X3)	45	4	6	33	34	28	30	24	M24×3	50-100
JBT2-B1(X3)	40	5	6	44	32	25	39	33	M33×3.5	200
JBT2-B2(X4)	45	5	6	47	34	27	39	32	M33×3.5	200
JBT3-B2(X4)	45	5	6	47	34	27	39	32	M33×3.5	300-500
JBT3-B3(X5)	42	5	6	47	34	27	39	32	M33×3.5	300-500
JBT4-B3(X5)	50	5	8	53	44	35	50	41.5	M42×4.5	1000-2000
JBT5-B3(X5)	55	5	8	58	49	39	60	51.5	M52×5	3000
JBT5-B4(X6)	55	5	8	58	49	39	60	51.5	M52×5	3000
JBT6-B4(X6)	75	9	8	65	52	42	70	61.5	M64×6	5000
JBT6-X7	75	9	8	65	52	42	70	61.5	M64×6	5000
JBT6-B5(X8)	75	9	8	65	52	42	70	61.5	M64×6	5000
JBT7-B5(X8)	74	8	10	89	52	44	90	79	M80×6	
JBT8-B6(X9)	48	9	10	90	60	52	100	89	M90×6	
JBT9-B7(X10)	50	10	10	100	50	46	110	99	M98×6	

注: JBT6 螺纹 M0 可做 M52×5, JBT7、JBT8、JBT9 螺纹 M0 可做 M80×2、M90×2、M98×2, 订货时请另注明。

5.2 DJ、LDJ型机架

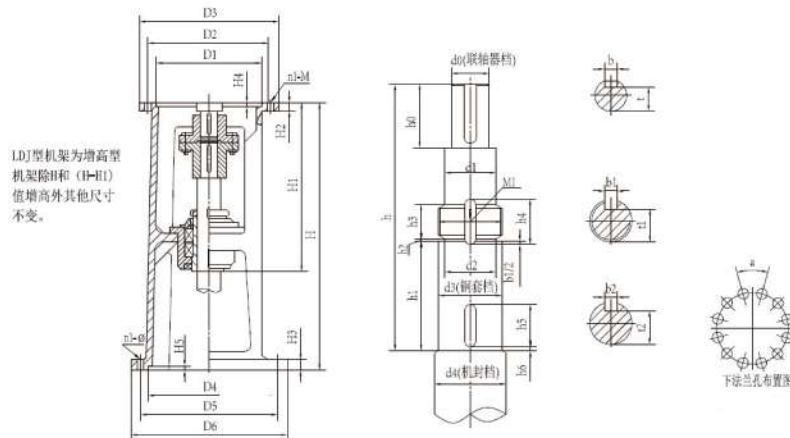

DJ、LDJ 型单支点机架主要参数及尺寸

机架型号	H1	H2	H3	H4	H5	输入端接口				输出端接口				
						D1	D2	D3	n1-M	D4	D5	6	α	n2-∅
DJ.LDJ30-B0	320	15	20	4	6	140	160	190	4-M10	240	285	315	30	12-∅14
DJ.LDJ30-B1(X3)	320	15	20	4	6	170	200	230	6-M12	240	285	315	30	12-∅14
DJ.LDJ35-B1(X3)	334	17	20	5	6	170	200	230	6-M10	260	320	360	30	12-∅14
DJ.LDJ40-B2(X4)	334	17	20	4	6	200	230	260	6-∅12	260	320	360	30	12-∅14
DJ.LDJ45-B2(X4)	338	20	20	5	6	200	230	260	6-∅12	260	320	360	30	12-∅14
DJ.LDJ55-B3(X5)	372	22	24	6	6	270	310	340	6-∅13.5	325	400	435	30	12-∅14
DJ.LDJ65-B4(X6)	447	22	24	6	6	320(316)	360	400	8-∅15	350	420	460	30	12-∅18
DJ.LDJ70-B4(X6)	447	22	24	6	6	320(316)	360	400	8-∅15	350	420	460	30	12-∅18
DJ.LDJ80-B4(X6)	495	22	28	6	8	320(316)	360	400	8-∅15	380	455	495	30	12-∅18
DJ.LDJ80-X7	495	22	28	6	8	345	390	430	8-∅18	380	455	495	30	12-∅18
DJ.LDJ80-B5(X8)	495	22	28	6	8	400	450	490	12-∅18	380	455	495	30	12-∅18
DJ.LDJ90-B5(X8)	519	22	28	7	8	400	450	490	12-∅18	430	510	555	30	12-∅23
DJ.LDJ100-B6(X9)	535	25	28	9	10	460(455)	520	580	12-∅22	480	560	600	22.5	16-∅23
DJ.LDJ110-B7(X10)	660	30	28	11	10	520	590	650	12-∅22	560	650	700	22.5	16-∅27
DJ.LDJ120-B7(X10)	660	30	28	11	10	520	590	650	12-∅22	560	650	700	22.5	16-∅27
DJ.LDJ130-B8(X11)	790	45	40	12	10	680	800	880	12-∅38	720	810	880	18	20-∅27
DJ.LDJ140-B8(X11)	790	45	40	12	12	680	800	880	12-∅38	720	810	880	18	20-∅27
DJ.LDJ180-B9(X12)	910	55	50	14	12	960	1080	1160	8-∅39	970	1080	1160	18	20-∅33

型号	搅拌轴轴端尺寸																				DJ 型 LDJ 型	
	h(B/X)	h0	h1	h2	h3	h4	h5	h6	d0	d1	d2	M1	d3(h9)	d4	b	t	b1	t1	b2	t2	H	
DJ.LDJ30-B0	250/254	53	103	3	13	22	30	3	30	32	32.8	M35×1.5	35	40	8	26	6	31	6	32	550	700
DJ.LDJ30-B1(X3)	250/254	53	103	3	13	22	30	3	30	32	32.8	M35×1.5	35	40	8	26	6	31	6	32	550	700
DJ.LDJ35-B1(X3)	253	53	113	3	15	24	40	3	35	42	42.8	M45×1.5	45	50	10	30	6	41	6	42	600	750
DJ.LDJ40-B2(X4)	242/249	69	113	3	15	24	40	3	40	42	42.8	M45×1.5	45	50	12	35	6	41	6	42	600	750
DJ.LDJ45-B2(X4)	246	69	113	3	15	28	40	3	45	47	47.8	M50×1.5	50	65	14	40	8	46	8	46	600	750
DJ.LDJ55-B3(X5)	274/272	80	118	4	15	27	40	3	55	57	57	M60×2	60	65	16	49	8	56	8	56	660	760
DJ.LDJ65-B4(X6)	333	87	143	4	18	32	50	3	65	71	72	M75×2	75	80	18	58	10	69	10	70	720	870
DJ.LDJ70-B4(X6)	333/327	87	143	4	18	32	50	3	70	71	72	M75×2	75	80	20	63	10	69	10	70	720	870
DJ.LDJ80-B4(X6)	371/340	91	163	4	18	32	60	3	80	81	82	M85×2	85	90	22	71	10	79	10	80	785	935
DJ.LDJ80-X7	371	91	163	4	18	32	60	3	80	81	82	M85×2	85	90	22	71	10	79	10	80	785	935
DJ.LDJ80-B5(X8)	365	91	163	4	18	32	60	3	80	81	82	M85×2	85	90	22	71	10	79	10	80	785	935
DJ.LDJ90-B5(X8)	375	125	168	4	20	36	60	3	90	91	92	M95×2	95	110	25	81	12	89	12	90	805	955
DJ.LDJ100-B6(X9)	386/360	134	178	4	24	42	60	3	100	111	112	M115×2	115	125	28	90	14	109	14	110	820	1020
DJ.LDJ110-B7(X10)	456	155	178	4	24	42	60	3	110	111	112	M115×2	115	125	28	100	14	109	14	110	1100	1150
DJ.LDJ120-B7(X10)	456	155	178	4	24	42	60	3	120	122	122	M125×2	125	140	32	109	14	119	14	120	1100	1150
DJ.LDJ130-B8(X11)	570	197	208	4	28	46	70	3	130	135	137	M140×2	140	150	32	119	14	132	14	135	1200	1400
DJ.LDJ140-B8(X11)	570	197	208	4	28	48	70	3	140	145	147	M150×2	150	160	36	128	16	142	16	144	1200	1400
DJ.LDJ180-B9(X12)	535	235	242	4	36	58	90	3	180	185	186	M190×3	190	200	45	165	18	180	18	182	1280	1400

注：增高后的 LDJ 型机架其下部空间高度可容纳 205、206、207 双端面机械密封。

5.3 SJ、LSJ型机架

LSJ型机架为增高型
机架除H和H2值增高
外其他尺寸不变。

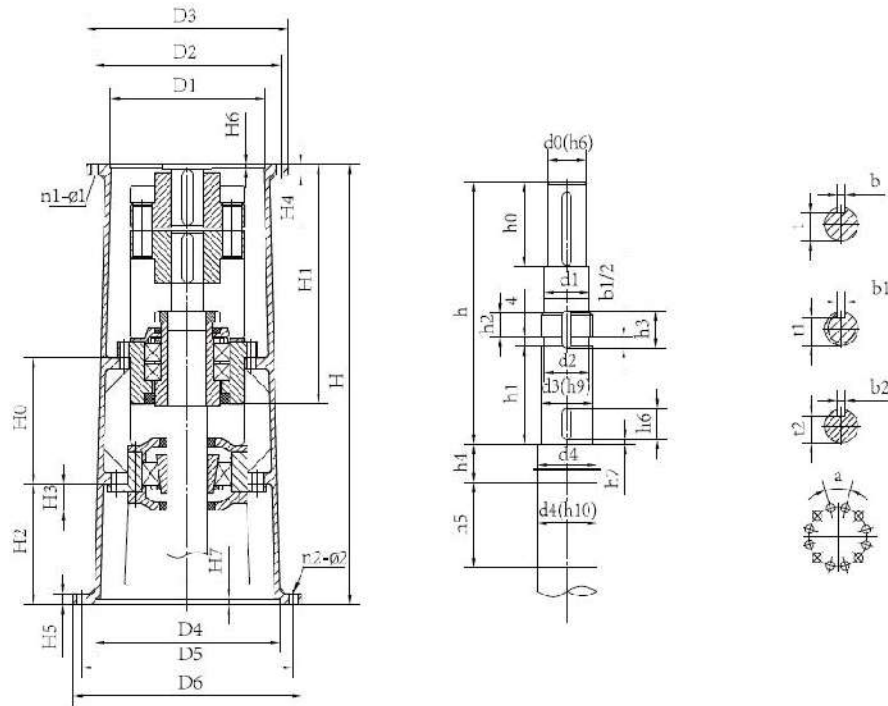

SJ、LSJ 型双支点机架主要参数及尺寸

机架代号	H0	H1	H3	H4	H5	H6	H7	D1	D2	D3	n1-φ1	D4	D5	D6	α°	n2-φ2
SJ.LSJ55-B3(X5)	450	402	58	22	24	6	6	270	310	340	6-φ13.5	325	400	435	30	12-φ14
SJ.LSJ65-B4(X6)	450	487	58	22	24	6	6	320(316)	360	400	8-φ15	350	420	460	30	12-φ18
SJ.LSJ70-B4(X6)	450	487	58	22	24	6	6	320(316)	360	400	8-φ15	350	420	460	30	12-φ18
SJ.LSJ80-B4(X6)	450	545	60	25	28	6	8	320(316)	360	400	8-φ15	380	455	495	30	12-φ23
SJ.LSJ80-X7	450	545	60	25	28	6	8	345	390	430	8-φ18	380	455	495	30	12-φ23
SJ.LSJ80-B5(X8)	450	545	60	25	28	6	8	400	450	490	12-φ18	380	455	495	30	12-φ23
SJ.LSJ90-B5(X8)	600	569	69	25	40	7	8	400	450	490	12-φ18	430	510	555	30	12-φ23
SJ.LSJ100-B6(X9)	600	685	61	30	40	9	10	460(455)	520	580	12-φ22	480	560	600	22.5	16-φ23
SJ.LSJ110-B7(X10)	600	685	61	38	40	11	10	520	590	650	12-φ22	560	650	700	22.5	16-φ27
SJ.LSJ120-B7(X10)	600	685	61	38	40	11	10	520	590	650	12-φ22	560	650	700	22.5	16-φ27
SJ.LSJ130-B8(X11)	650	761	85	40	45	11	10	680	800	880	12-φ38	720	810	880	18	20-φ27
SJ.LSJ140-B8(X11)	650	761	85	40	45	11	12	680	800	880	12-φ38	720	810	880	18	20-φ27
SJ.LSJ180-B9(X12)	650	910	83	50	80	14	12	960	1080	1160	8-φ39	840	1080	1160	18	20-φ33

机架代号	搅拌轴轴端尺寸																				SJ型		LSJ型		
	h(B/X)	h0	h1	h2	h3	h4	h5	h6	h7	d0	d1	d2	M0	d3(h9)	d4	b	t	b1	t1	b2	t2	H	H2	H	H2
SJ.LSJ55-B3(X5)	307/302	80	118	15	24	300	120	40	3	55	57	57	M60×2	60	65	16	49	8	56	8	56	1070	312	1220	462
SJ.LSJ65-B4(X6)	373	95	143	18	32	275	135	50	3	65	72	72	M75×2	75	80	18	58	10	69	10	70	1140	307	1290	457
SJ.LSJ70-B4(X6)	373/367	95	143	18	32	275	135	50	3	70	72	72	M75×2	75	80	20	63	10	69	10	70	1140	307	1290	457
SJ.LSJ80-B4(X6)	422	95	163	18	32	250	139	60	3	80	81	82	M85×2	85	90	22	71	10	79	10	80	1230	354	1380	504
SJ.LSJ80-X7	422	95	163	18	32	250	139	60	3	80	81	82	M85×2	85	90	22	71	10	79	10	80	1230	354	1380	504
SJ.LSJ80-B5(X8)	418	95	163	18	32	250	139	60	3	80	81	82	M85×2	85	90	22	71	10	79	10	80	1230	354	1380	504
SJ.LSJ90-B5(X8)	436	115	168	20	36	380	162	60	3	90	91	92	M95×2	95	110	25	81	12	89	12	90	1400	363	1550	513
SJ.LSJ100-B6(X9)	532/510	135	178	24	42	360	182	60	3	100	110	112	M115×2	115	125	28	90	14	109	14	109.5	1510	350	1710	550
SJ.LSJ110-B7(X10)	489	145	178	24	42	380	182	60	3	110	111	112	M115×2	115	125	28	100	14	109	14	109.5	1510	350	1710	550
SJ.LSJ120-B7(X10)	489	145	178	24	42	380	182	60	3	120	122	122	M125×2	125	140	32	109	14	119	14	119.5	1510	350	1710	550
SJ.LSJ130-B8(X11)	537	205	208	28	46	370	200	70	3	130	135	137	M140×2	140	150	32	119	14	132	14	134.5	1610	374	1810	574
SJ.LSJ140-B8(X11)	537	205	208	28	48	370	200	70	3	140	145	147	M150×2	150	160	36	128	16	142	16	144	1610	374	1810	574
SJ.LSJ180-B9(X12)	535	290	242	36	58	310	230	90	3	180	185	186	M190×3	190	200	45	165	18	180	18	182	1710	402	1920	602

注：增高后的LSJ型机架其下部空间高度可容纳205、206、207双端面机械密封。

5.4 DXJ型机架

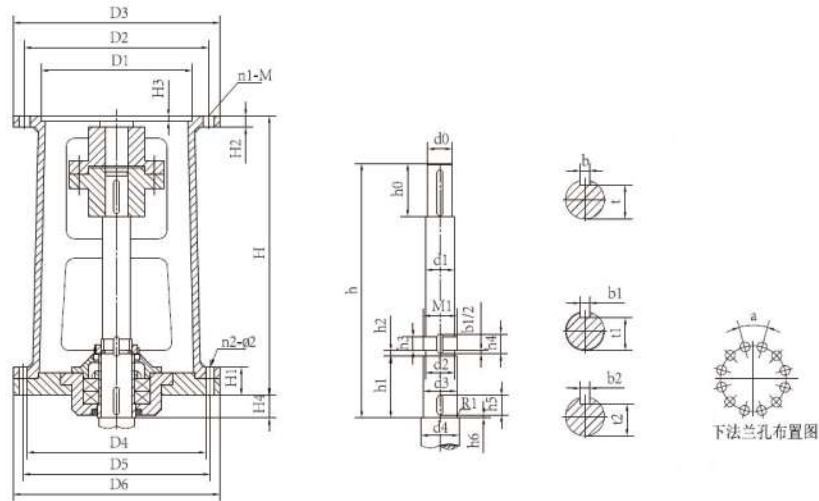

DXJ 型单支点机架主要参数及尺寸

机架型号	H	H1	H2	H3	H4	输入端接口				输出端接口				
						D1	D2	D3	n1-M	D4	D5	D6	α	n2- ϕ
DXJ30-B0	470	40	15	4	45	140	160	190	4-M10	240	285	315	30	12- ϕ 14
DXJ30-B1(X3)	470	40	15	4	45	170	200	230	6- ϕ 12	240	285	315	30	12- ϕ 14
DXJ35-B1(X3)	524	48	15	5	47	170	200	230	6-M10	260	320	360	30	12- ϕ 14
DXJ40-B2(X4)	524	48	15	4	47	200	230	260	6- ϕ 12	260	320	360	30	12- ϕ 14
DXJ45-B2(X4)	524	48	15	5	49	200	230	260	6- ϕ 12	260	320	360	30	12- ϕ 14
DXJ55-B3(X5)	580	55	20	6	47	270	310	340	6- ϕ 13.5	325	400	435	30	12- ϕ 14
DXJ65-B4(X6)	634	60	20	6	58	320(316)	360	400	8- ϕ 15	350	420	460	30	12- ϕ 18
DXJ70-B4(X6)	634	60	20	6	58	320(316)	360	400	8- ϕ 15	350	420	460	30	12- ϕ 18
DXJ80-B4(X6)	678	65	25	6	70	320(316)	360	400	8- ϕ 15	380	455	495	30	12- ϕ 18
DXJ80-X7	678	65	25	6	70	345	390	430	8- ϕ 18	380	455	495	30	12- ϕ 18
DXJ80-B5(X8)	678	65	25	6	70	400	450	490	12- ϕ 18	380	455	495	30	12- ϕ 18
DXJ90-B5(X8)	700	75	2	7	72	400	450	490	12- ϕ 18	430	510	555	30	12- ϕ 23
DXJ100-B6(X9)	740	80	25	9	76	460(455)	520	580	12- ϕ 22	480	460	600	22.5	16- ϕ 23
DXJ110-B7(X10)	840	80	30	11	76	520	590	650	12- ϕ 22	560	650	700	22.5	16- ϕ 27
DXJ120-B7(X10)	840	80	30	11	76	520	590	650	12- ϕ 22	560	650	700	22.5	16- ϕ 27
DXJ130-B8(X11)	950	94	30	11	85	680	800	880	12- ϕ 38	720	810	880	18	20- ϕ 27
DXJ140-B8(X11)	950	94	30	11	85	680	800	880	12- ϕ 38	720	810	880	18	20- ϕ 27
DXJ180-B9(X12)	1050	100	40	14	115	960	1080	1160	8- ϕ 39	970	1080	1160	18	20- ϕ 33

机架型号	搅拌轴轴端尺寸																			
	h(B/X)	h0	h1	h2	h3	h4	h5	h6	d0	d1	d2	M1	d3	d4	b	t	b1	t1	b2	t2
DXJ30-B0	431/445	53	103	3	13	22	30	3	30	32	32.8	M35×1.5	35	40	8	26	6	31	6	31.5
DXJ30-B1(X3)	431/445	53	103	3	13	22	30	3	30	32	32.8	M35×1.5	35	40	8	26	6	31	6	31.5
DXJ35-B1(X3)	490	53	113	3	15	24	40	3	35	42	42.8	M45×1.5	45	50	10	30	6	41	6	41.5
DXJ40-B2(X4)	479/482	69	113	3	15	24	40	3	40	42	42.8	M45×1.5	45	50	12	35	6	41	6	41.5
DXJ45-B2(X4)	481	69	113	3	15	28	40	3	45	47	47.8	M50×1.5	50	65	14	39.5	8	46	8	46
DXJ55-B3(X5)	530	80	118	4	15	27	40	3	55	57	57	M60×2	60	65	16	49	8	56	8	56
DXJ65-B4(X6)	590	87	143	4	18	32	50	3	65	71	72	M75×2	75	80	18	58	10	69	10	70
DXJ70-B4(X6)	590/580	87	143	4	18	32	50	3	70	71	72	M75×2	75	80	20	62.5	10	69	10	70
DXJ80-B4(X6)	630/590	91	163	4	18	32	60	3	80	81	82	M85×2	85	90	22	71	10	79	10	80
DXJ80-X7	630/590	91	163	4	18	32	60	3	80	81	82	M85×2	85	90	22	71	10	79	10	80
DXJ80-B5(X8)	618	91	163	4	18	32	60	3	80	81	82	M85×2	85	90	22	71	10	79	10	80
DXJ90-B5(X8)	636	125	168	4	20	36	60	3	90	91	92	M95×2	95	110	25	81	12	89	12	90
DXJ100-B6(X9)	667/635	134	178	4	24	42	60	3	100	111	112	M115×2	115	125	28	90	14	109	14	110
DXJ110-B7(X10)	712	155	178	4	24	42	60	3	110	111	112	M115×2	115	125	28	100	14	109	14	110
DXJ120-B7(X10)	712	155	178	4	24	42	60	3	120	122	122	M125×2	125	140	32	109	14	119	14	120
DXJ130-B8(X11)	815	197	208	4	28	46	70	3	130	135	137	M140×2	140	150	32	119	14	132	14	135
DXJ140-B8(X11)	815	197	208	4	32	52	70	3	140	145	147	M150×2	150	160	36	128	16	142	16	144
DXJ180-B9(X12)	790	290	242	4	36	58	90	3	180	180	186	M190×3	190	200	45	165	18	180	18	182

5.5 JXD型机架

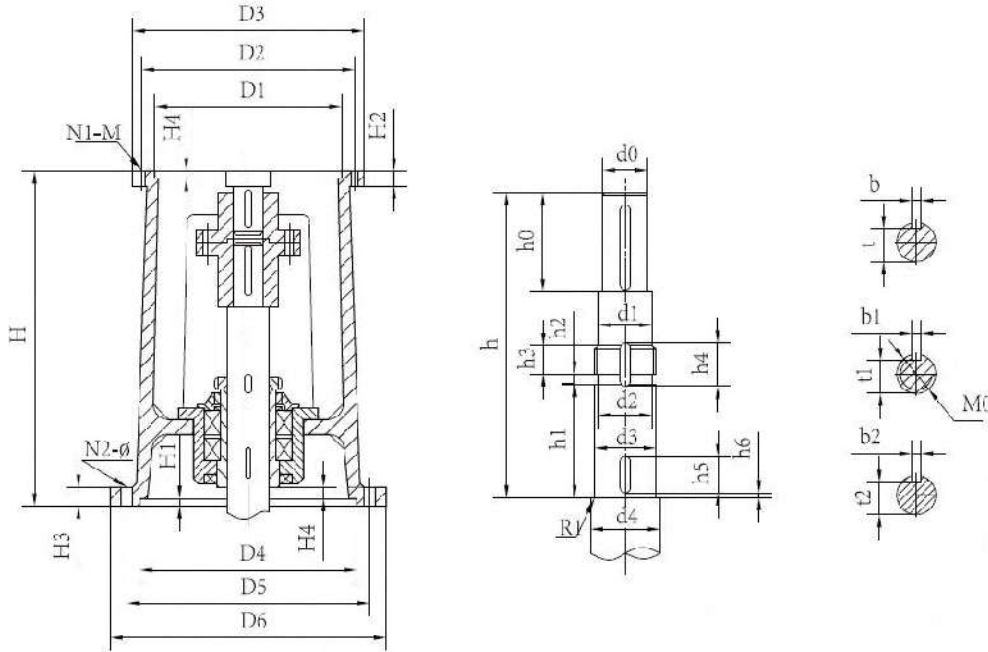

JXD 型单支点机架主要参数及尺寸

机架型号	H	H1	H2	H3	H4	输入端接口				输出端接口			
						D1	D2	D3	N1-M	D4	D5	D6	n2-φ
JXD35-B1(X3)	450	6	15	24	32	170	200	230	6-M10	315	362	405	12-φ18
JXD40-B2(X4)	450	6	15	24	32	200	230	260	6-M10	315	362	405	12-φ18
JXD45-B2(X4)	450	6	15	24	22	200	230	260	6-M10	315	362	405	12-φ18
JXD55-B3(X5)	450	8	20	28	25	270	310	340	6-φ13.5	315	362	405	12-φ18
JXD70-B4(X6)	500	8	20	28	23	320(316)	360	400	8-φ15	325	390	435	12-φ18
JXD80-B4(X6)	540	8	25	30	9	320(316)	360	400	8-φ15	365	432	485	12-φ23
JXD80-X7	540	8	25	30	9	345	390	430	8-φ18	365	432	485	12-φ23
JXD90-B5(X8)	580	8	25	30	20	400	450	490	12-φ18	400	476	565	12-φ26
JXD100-B6(X9)	580	8	25	35	15	460(455)	520	580	12-φ22	400	476	565	12-φ26
JXD110-B7(X10)	650	10	30	40	15	520	590	650	12-φ22	480	540	685	12-φ26
JXD120-B7(X10)	650	10	30	40	15	520	590	650	12-φ22	480	540	685	12-φ26
JXD130-B8(X11)	800	10	45	45	20	680	800	880	12-φ38	560	635	880	20-φ27
JXD140-B8(X11)	800	10	45	45	20	680	800	880	12-φ38	560	635	880	20-φ27

机架型号	搅拌轴轴端尺寸																				
	h (B/X)	h1	h2	h3	h4	h5	h6	h0	d0	d1	d2	M0	d3	d4	R1	b	t	b1	t1	b2	t2
JXD35-B1(X3)	340	113	3	15	24	40	3	53	35	42	42.8	M45×1.5	45	50	1	10	30	6	41	6	41.5
JXD40-B2(X4)	324	113	3	15	24	40	3	69	40	42	42.8	M45×1.5	45	50	1	12	35	6	41	6	41.5
JXD45-B2(X4)	334	113	3	15	28	40	3	69	45	47	47	M50×1.5	50	65	1	14	39.5	8	46	8	46
JXD55-B3(X5)	325	118	4	15	28	40	3	80	55	57	57	M60×2	60	65	1	16	49	8	56	8	56
JXD70-B4(X6)	355	143	4	18	32	50	3	87	65	71	72	M75×2	75	80	1	18	58	10	69	10	70
JXD80-B4(X6)	363	163	4	18	32	60	3	91	80	82	82	M85×2	85	90	1.5	22	71	10	79	10	80
JXD80-X7	411	163	4	18	32	60	3	91	80	82	82	M85×2	85	90	1.5	22	71	10	79	10	80
JXD90-B5(X8)	415	168	4	20	36	60	3	125	90	92	92	M95×2	95	110	1.5	25	81	12	89	12	90
JXD100-B6(X9)	410/385	178	4	24	42	60	3	134	100	111	112	M115×2	115	125	2	28	90	14	109	14	109.5
JXD110-B7(X10)	431	178	4	24	42	60	3	155	110	112	112	M115×2	115	125	2	28	100	14	109	14	109.5
JXD120-B7(X10)	431	178	4	24	42	60	3	155	120	122	122	M125×2	125	140	2	32	109	14	119	14	119.5
JXD130-B8(X11)	560	208	4	28	46	70	3	197	130	135	137	M140×2	140	150	2	32	119	14	132	14	134.5
JXD140-B8(X11)	560	208	4	28	46	70	3	197	140	145	146	M150×2	150	160	2	36	128	16	142	16	144

5.6 JXLD型机架 (74标) (天津标)

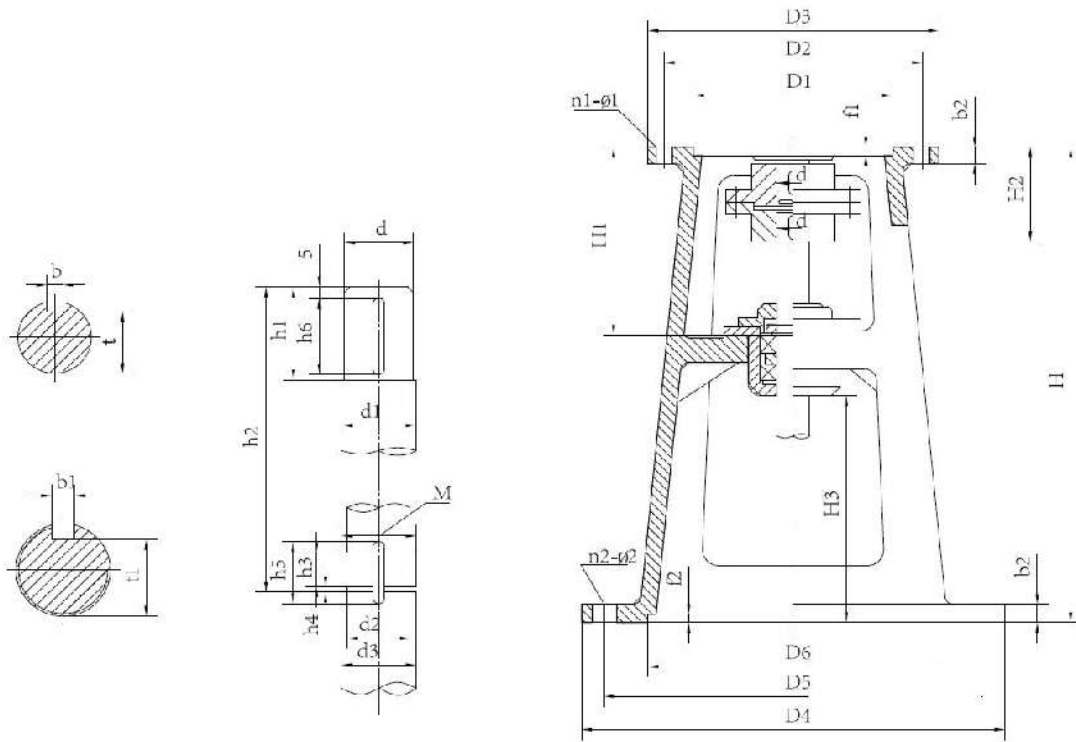

JXLD 型 (74 标) 机架主要参数及尺寸

机架 型号	d	搅拌轴轴端尺寸													输入端接口尺寸					输出端接口尺寸				H1	H2	H3	H			
		d1	M	d2	d3 (k6)	h1	h2	h3	h4	h5	h6	b	t	b1	t1	D3	D2	D1	f1	b2	n1- ϕ 1	D4	D5					D6 (H9)	f2	n2- ϕ 2
JXLD3	35	40	M45×1.5	43	45	60	215	10	3	16	50	10	30	6	41	230	200	170	4	18	6-12	410	360	300	6	6-18	291	136	170	520
JXLD4	45	50	M55×2	52	55	75	235	14	4	22	69	14	40	8	51	260	230	200	4	18	6-12	450	400	335	6	6-18	335	175	155	570
JXLD5	55	60	M65×2	62	65	75	301	14	4	22	70	16	49	8	61	340	310	270	6	22	6-13	500	450	385	6	8-18	404	178	157	650
JXLD6	65	70	M75×2	72	75	90	277	16	4	25	85	18	58	10	70	400	360	316	6	22	8-16	530	480	410	6	12-18	402	215	168	660
JXLD7	80	85	M90×2	87	90	105	316	20	4	30	100	22	71	12	84	430	390	345	6	24	8-18	565	510	430	8	12-22	441	230	194	740
JXLD8	90	95	M100×2	97	100	125	320	20	4	30	120	25	81	12	94	490	450	400	7	28	12-18	565	510	430	8	12-22	471	276	212	800
JXLD9	100	105	M110×2	107	110	125	308	20	4	31	120	28	90	14	104	580	520	455	9	30	12-22	580	520	455	10	12-22	496	313	191	810
JXLD10	110	115	M120×2	117	120	155	267	24	4	35	150	28	100	14	114	650	590	520	11	30	12-22	650	590	520	10	12-22	475	363	221	830
JXLD11	130	135	M140×2	137	140	155	301	28	4	39	150	32	119	14	132	880	800	680	12	30	12-38	880	800	680	12	12-37	521	375	185	850
JXLD12	180	190	M200×2	196	200	284	377	36	4	48	280	45	165	16	190	1160	1020	900	14	45	8-39	1160	1020	900	12	8-39	757	664	235	1200

5.7 TJ型机架

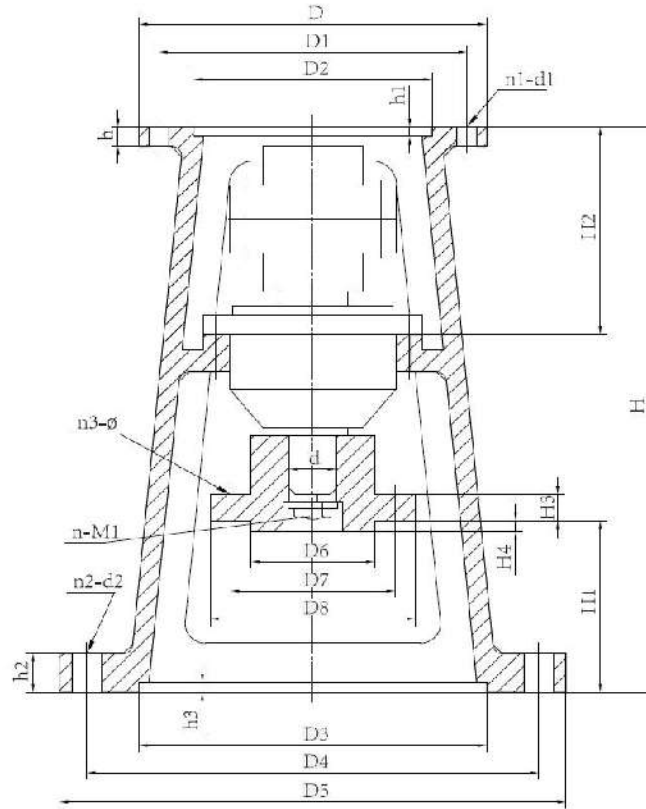

TJ 型机架，下装 JA 型联轴器，主要参数及尺寸

机架型号	输入端接口						输出端接口						H	H1	H2	H3	d	D6	D7	D8	n3-ø	n-M1
	D	D1	D2	h	h1	n1-d1	D3	D4	D5	h2	h3	n2-d2										
TJ1-B1(X3)	230	200	170	20	6	6-12	220	270	305	22	7	4-24	514	201	185	15	35	60	110	140	4-13.5	1-10
TJ2-B1(X3)	230	200	170	20	6	6-12	250	300	335	22	7	4-24	517	197	190	15	35	60	110	140	4-13.5	1-10
TJ2-B2(X4)	260	230	200	20	7	6-13	250	300	335	25	7	4-24	530	176	210	20	45	85	120	160	4-13.5	1-12
TJ3-B2(X4)	260	230	200	20	7	6-13	295	350	392	26	7	4-26	560	206	210	20	45	85	120	160	4-13.5	1-12
TJ3-B3(X5)	340	310	270	20	7	6-13	295	350	392	26	7	4-26	560	191	210	20	45	85	120	160	4-13.5	1-12
TJ4-B3(X5)	340	310	270	20	7	6-13	345	400	442	26	7	4-26	635	245	215	22	55	100	150	180	4-18	1-16
TJ5-B3(X5)	340	310	270	22	7	6-13	390	450	498	26	7	4-30	635	250	215	22	55	100	150	180	4-18	1-16
TJ6-B4(X6)	400	360	320(316)	22	7	8-16	435	500	548	30	7	8-30	736	276	250	28	70	110	165	200	4-18	1-16
TJ7-B5(X8)	490	450	400	26	10	12-18	440	550	600	30	10	12-22	805	241	296	36	90	150	190	230	6-18	1-16
TJ8-B6(X9)	580	520	460(455)	28	10	12-22	500	550	600	32	10	12-22	820	192	362	36	100	140	200	240	6-18	1-16
TJ9-B7(X10)	650	590	520	30	12	12-22	560	650	700	35	10	12-27	1100	355	455	36	110	150	250	290	6-27	1-16
TJ10-B8(X11)	880	800	680	45	12	12-38	720	810	880	45	10	20-27	1200	304	550	40	130	180	290	350	6-27	1-16

注：TJ6、TJ7 均可配 XL7 号减速机，订货时请另注明。

5.8 TJQ型机架

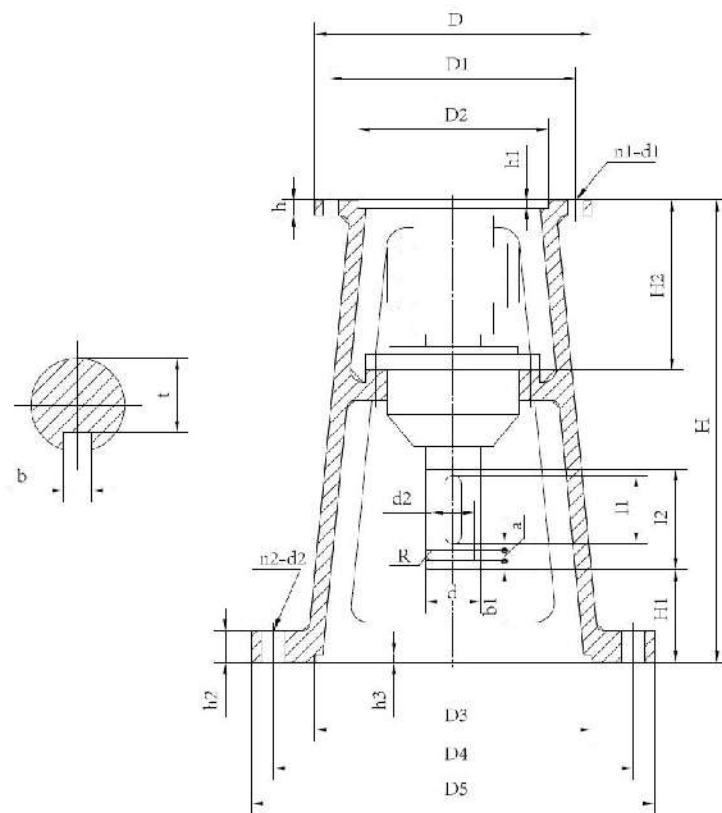

TJQ 型机架，下装 JQ 夹壳式联轴器，主要参数及尺寸

机架型号	d (h7)	输入端接口						输出端接口						H	H1	H2	l1	l2	a (H11)	b1	d2 (h11)	b	t	配联 轴器 型号
		D	D1	D2	h	h1	n1-d1	D3	D4	D5	h2	h3	n2-d2											
TJQ1-B1(X3)	35	230	200	170	18	5	6-12	220	270	305	22	7	4-24	514	173	185	55	85	5	4	30	10	30	JQ35
TJQ2-B1(X3)	35	230	200	170	20	6	6-13.5	250	300	335	22	7	4-24	517	182	190	55	85	5	4	30	10	30	JQ35
TJQ2-B2(X4)	45	260	230	200	20	6	6-13.5	250	300	335	22	7	4-24	530	175	210	70	100	6	5	37	14	39.5	JQ45
TJQ3-B2(X4)	45	260	230	200	20	6	6-13.5	295	350	392	25	7	4-26	560	191	210	70	100	6	5	37	14	39.5	JQ45
TJQ3-B3(X5)	45	340	310	270	20	6	6-13.5	295	350	392	26	7	4-26	560	191	210	70	100	6	5	37	14	39.5	JQ45
TJQ4-B3(X5)	55	340	310	270	20	6	6-13.5	345	400	442	26	7	4-26	635	253	210	70	100	6	5	47	16	49	JQ55
TJQ5-B3(X5)	55	340	310	270	20	6	6-13.5	390	450	498	26	7	4-30	635	258	215	70	100	6	5	47	16	49	JQ55
TJQ6-B4(X6)	70	400	360	320(316)	22	6	8-16	435	500	548	26	7	8-30	736	284	250	100	130	8	6	60	20	62.5	JQ70
TJQ7-B5(X8)	90	490	450	400	25	7	12-18	440	550	600	28	10	12-22	805	233	296	140	170	10	8	80	25	81	JQ90
TJQ8-B6(X9)	100	580	520	460(455)	26	10	12-22	500	550	600	30	10	12-22	820	187	362	140	170	10	8	90	28	90	JQ100
TJQ9-B7(X10)	110	650	590	520	30	12	12-22	560	650	700	40	10	12-27	1100	210	455	160	200	12	10	100	28	100	JQ110
TJQ10-B8(X11)	130	880	800	680	40	12	12-38	720	810	880	45	10	20-27	1200	297	550	180	225	14	12	118	32	119	JQ120

5.9 TJA (新标) 型机架

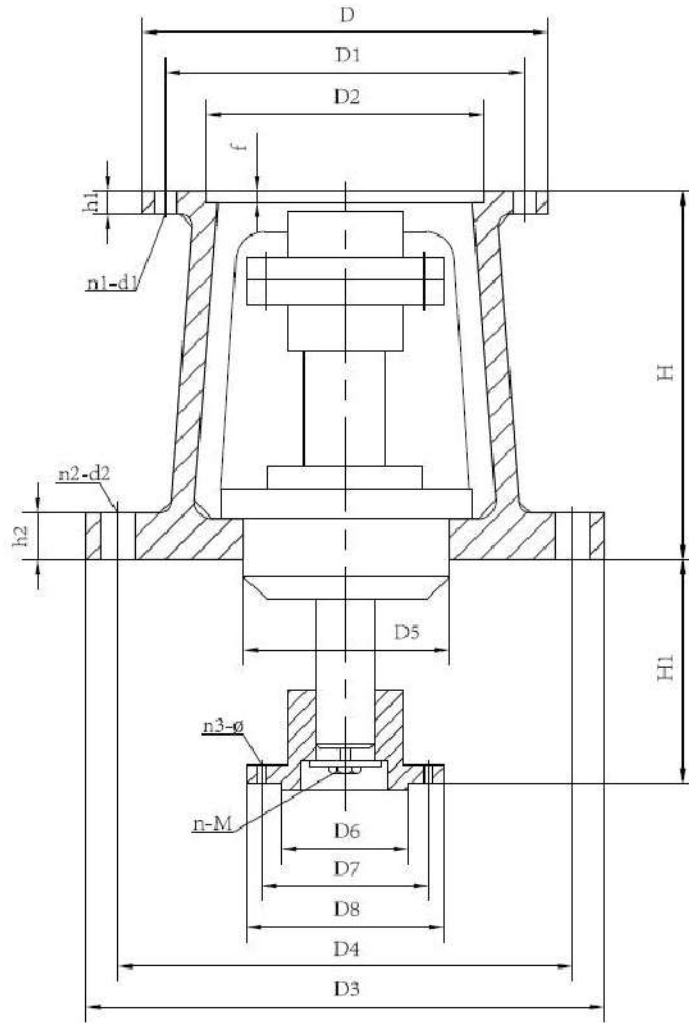

TJA 型 (新标) 机架主要参数及尺寸

机架 型号	减速机 型号	输入端接口						输出端接口				H	H1	D5	D6	D7	D8	n3-φ	n-M
		D	D1	D2	h1	f	n1-d1	D3	D4	h2	n2-d2								
TJA1	B1(X3)	230	200	170	16	5	6-12	270	235	17	4-12	215	115	115	60	110	140	4-12	1-10
TJA2	B2(X4)	260	230	200	20	6	6-12	310	270	20	4-18	240	135	115	85	120	160	4-13	1-12
TJA3	B3(X5)	340	310	270	22	6	6-14	370	320	22	4-20	290	162	160	100	150	180	4-18	1-12
TJA4	B4(X6)	400	360	320(316)	22	7	8-16	455	400	24	6-20	315	185	160	110	165	200	4-18	1-16
TJA5	B5(X8)	490	450	400	25	7	12-18	545	495	26	8-22	332	230	240	150	190	230	6-18	1-20
TJA6	B6(X9)	580	520	460(455)	25	10	12-22	600	550	35	12-22	400	210	245	140	200	240	6-18	1-20
TJA7	B7(X10)	650	590	520	25	11	12-22	680	620	35	12-22	450	240	270	150	250	290	6-27	1-20

5.10 JAI大法兰机架（69标）与JAIII搪玻璃反应罐专用机架（69标）

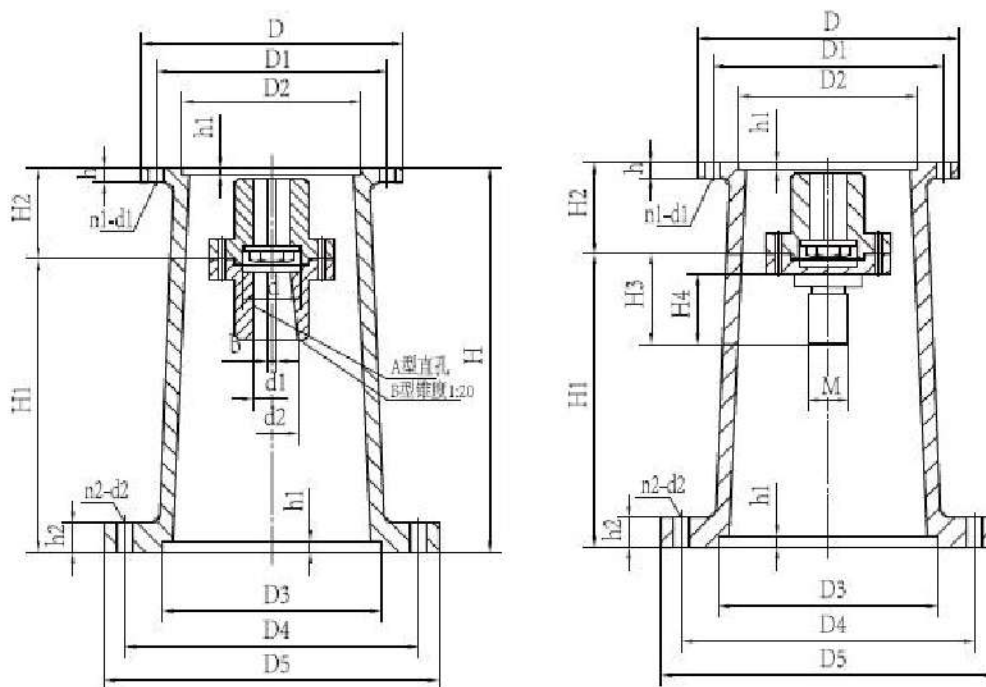

JAI 型（69 标）无支点机架主要参数及尺寸

机架 型号	减速机 型号	输入端接口						输出端接口					H1	H2	H3	H4	d	A型直孔		B型锥孔1: 20	
		D	D1	D2	h	h1	n1-d1	D3	D4	D5	h2	n2-d2						d1	b	d2	b
JAI0	B0(X2)	190(180)	160	140(130)	16	5	4-12(6-M10)	165	210	250	16	6-12	205	55	55	18	45	30(25)	8		
JAI1	B1(X3)	230	200	170	16	5	6-12	215	260	290	16	8-12	226	84	75	25	50	35	10	35	10
JAI2	B2(X4)	260	230	200	20	6	6-12	290	350	380	20	8-14	250	96	90	30	70	45	14	50	14
JAI3	B3(X5)	340	310	270	22	6	6-13.5	360	440	480	22	8-18	300	112	110	30	80	55	16	60	16
JAI4	B4(X6)	400	360	320(316)	22	7	8-15	440	530	580	25	8-22	384	141	130	40	90	70(65)	20	70	20
JAI5	B5(X8)	490	450	400	25	7	12-18	450	550	600	28	8-22	390	160	150	40	115	90	25	85	25

注：本机架配刚性联轴器，上联轴器为JA型直孔，下联轴器为JA型直孔或B型锥孔，锥度为1:20。该机架无支撑，在反应器传来的轴向力不大的情况下使用。

JAIII（69 标）无支点机架，配螺纹联轴器主要参数及尺寸

机架 型号	减速机 型号	输入端接口						输出端接口					H1	H2	H3	H4	M	反应罐 容积(升)
		D	D1	D2	h	h1	n1-d1	D3	D4	D5	h2	n2-d2						
JAI1	B1(X3)	230	200	170	16	5	6-12	215	260	290	16	8-12	226	84	93	50	M33×2	50-100
																	120	60
JAI2	B2(X4)	260	230	200	20	6	6-12	230	300	345	20	4-18	254	96	120	60	M42×3	200-300
																	M48×3	500
JAI3	B3(X5)	340	310	270	22	6	6-13.5	320	400	460	22	4-20	328	112	120	80	M60×4	1000
																	M68×4	1500
																	M78×4	2000
JAI4	B4(X6)	400	360	320(316)	22	7	8-15	440	530	580	25	8-22	384	141	130	80	M78×4	3000
JAI5	B5(X8)	490	450	400	25	7	12-18	450	550	600	28	8-22	390	160	130	80	M78×4	5000

注：JA4 均可配 XL7 号减速机，订货时请另注明。



✉ sales@guomaoreducer.com

☎ 400-112-5588

📍 中国江苏省常州市武进高新区龙潜路98号

🌐 www.guomaoreducer.com



江苏国茂减速机股份有限公司版权所有, 未经许可前, 禁止复制或使
用文本任何部分
Without the express approval of limited are not allowed to alter or use manual pictures and layout

传动精品 传递真情